



| <i>Section</i> | <i>Page No.</i> |
|---|--------------------|
| INTRODUCTION | 1 |
| PURPOSE OF MACHINE | 2 |
| MACHINE DIMENSIONS & SPECIFICATIONS | 2 |
| PARTS LOCATION DIAGRAMS | 3 & 4 |
| SAFE WORKING | 5 |
| Operator's Personal Protective Equipment Required | 5 |
| Basic Woodchipping Safety | 5 |
| General Safety Matters - Do's and Dont's | 6 |
| Noise Test | 7 |
| OPERATING INSTRUCTIONS | 8 |
| Safe Transportation | 8 |
| Delivery | 8 |
| Operator's Personal Protective Equipment Required | 8 |
| Manual Controls | 8 |
| Starting the Engine | 8 |
| Stopping the Engine | 9 |
| Emergency Stopping | 9 |
| Daily Checks Before Starting | 9 |
| Starting to Chip | 9 |
| Chipping | 9 |
| Blade Wear | 10 |
| Blockages | 10 |
| SERVICE INSTRUCTIONS | 11 |
| Service Schedule | 12 |
| Safe Maintenance | 13 |
| Safe Lifting of Chipper | 13 |
| Spares | 13 |
| Copper Ease Safety Information | 13 |
| Engine Manufacturer's Handbook | 13 |
| Change Blades | 14 |
| Check Fittings | 15 |
| Tension Drive Belts | 15 |
| Greasing Rotor Bearings | 15 |
| Anvil Changing | 15 |
| WARRANTY STATEMENT | 16 |
| EC DECLARATION OF CONFORMITY CERTIFICATE | 17 |
| IDENTIFICATION PLATES | 18 |
| DECALS | 19 & 20 |
| PARTS LISTS | 22 - 27 |



INTRODUCTION

Thank you for choosing this Timberwolf brushwood chipper. Timberwolf chippers are designed to give safe and dependable service if operated according to the instructions.

IMPORTANT HEALTH AND SAFETY INFORMATION

Before using your new chipper, please take time to read this manual which contains and explains the chipper controls. Failure to do so could result in:

- PERSONAL INJURY
- EQUIPMENT DAMAGE
- DAMAGE TO PROPERTY
- A MEMBER OF THE GENERAL PUBLIC BECOMING INJURED

This manual covers the operation and maintenance of the Timberwolf TW 13/75G. All information in this manual is based on the latest product information available at the time.

All the information you need to operate the machine safely and effectively is contained within pages 2 to 10. Ensure that all operators are **properly trained** for operating this machine, especially with regard to **safe working practices**.

Timberwolf's policy of constantly improving their products may involve major or minor changes to the chippers or their accessories. Timberwolf reserves the right to make changes at any time without notice and without incurring any obligation.

Due to improvements in design and performance during production there may be, in some cases, minor discrepancies between the actual chipper and the text in this manual.

The manual should be considered a permanent part of the machine and should remain with it if the machine is resold.

ALWAYS FOLLOW SAFE OPERATING AND MAINTENANCE PRACTICES



CAUTION or WARNING

BE AWARE OF THIS SYMBOL AND WHERE SHOWN, CAREFULLY FOLLOW THE INSTRUCTIONS.

This caution symbol indicates important safety messages in this manual. When you see this symbol, be alert to the possibility of injury to yourself or others, and carefully read the message that follows.



The Timberwolf TW 13/75G

Designed to chip solid wood material up to 75mm in diameter and capable of chipping over 0.75 tonnes of brushwood per hour.

DIMENSIONS

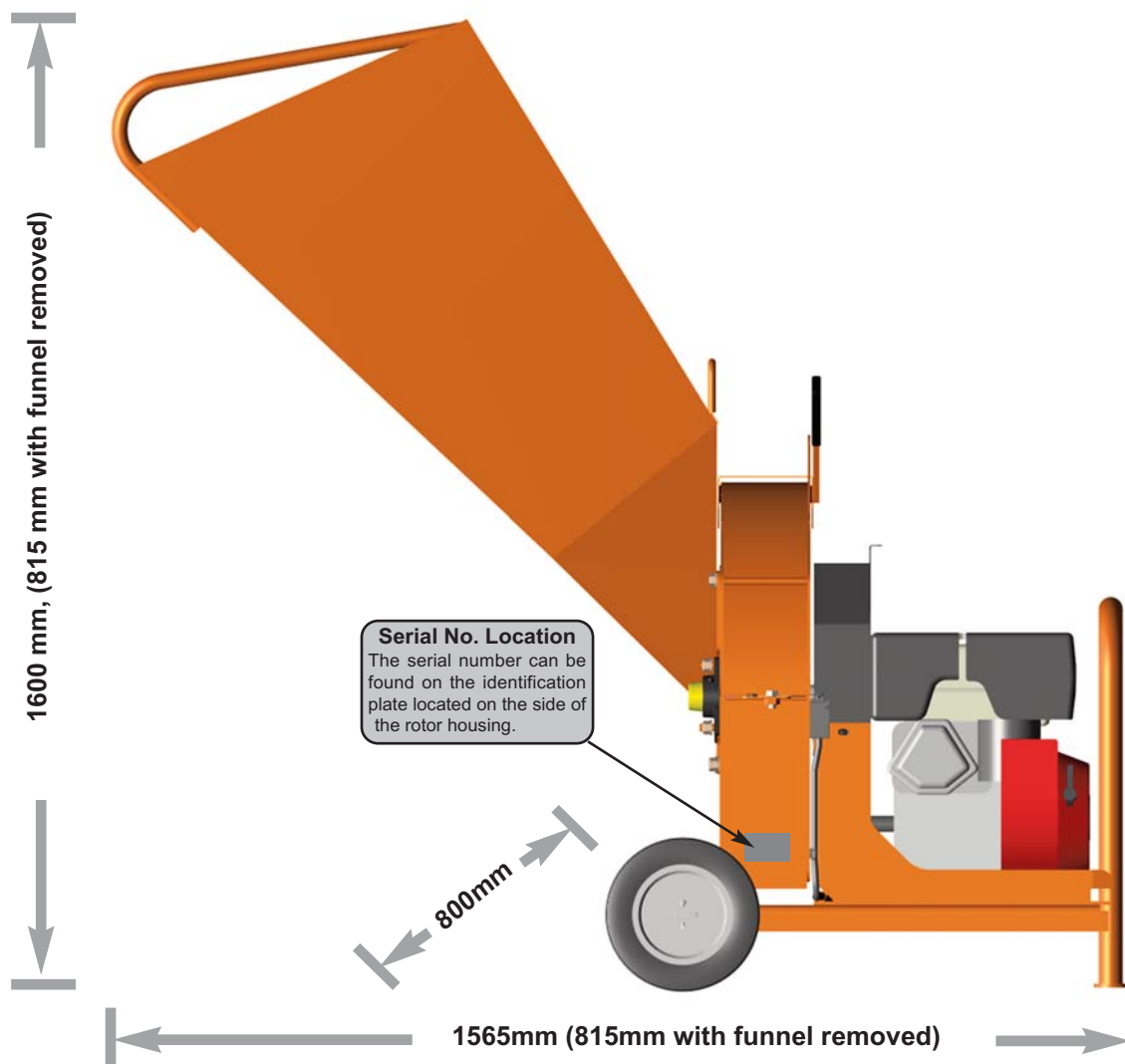

TIMBERWOLF TW 13/75G SPECIFICATION

| | | | |
|-------------------------|---------------------------|--------------------------------------|------------------------|
| Engine type: | <i>Honda 4 stroke OHV</i> | Maximum diameter material: | <i>75 mm (3")</i> |
| Maximum power: | <i>9.6kW (13hp)</i> | Fuel capacity: | <i>6.5 litres</i> |
| Cooling method: | <i>Air cooled</i> | Material processing capacity: | <i>0.75 tonnes/hr</i> |
| Overall weight: | <i>188kg</i> | Fuel type: | <i>Unleaded petrol</i> |
| Starting method: | <i>Recoil</i> | | |
| Type of feed: | <i>Gravity</i> | | |



PARTS LOCATOR

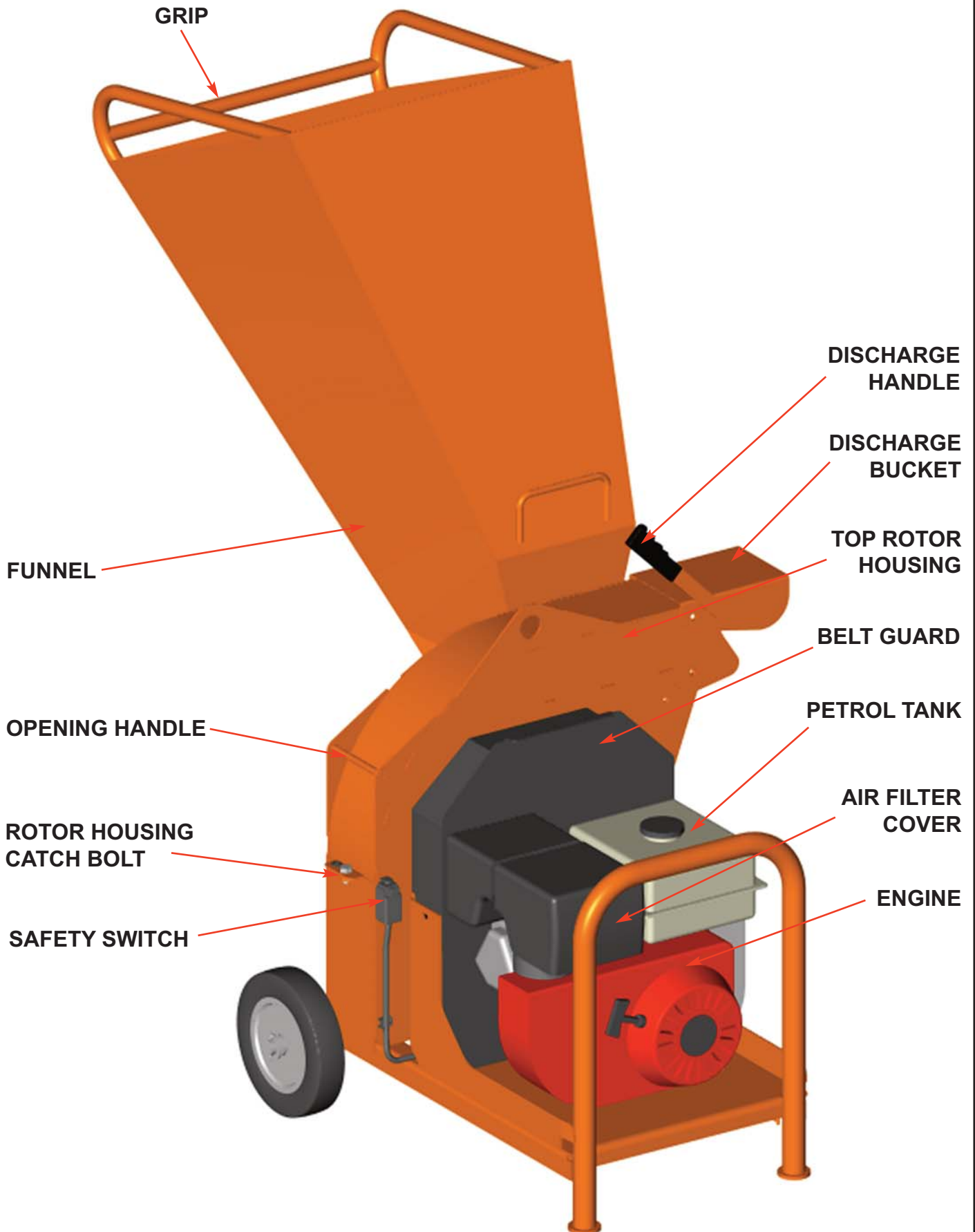



PARTS LOCATOR

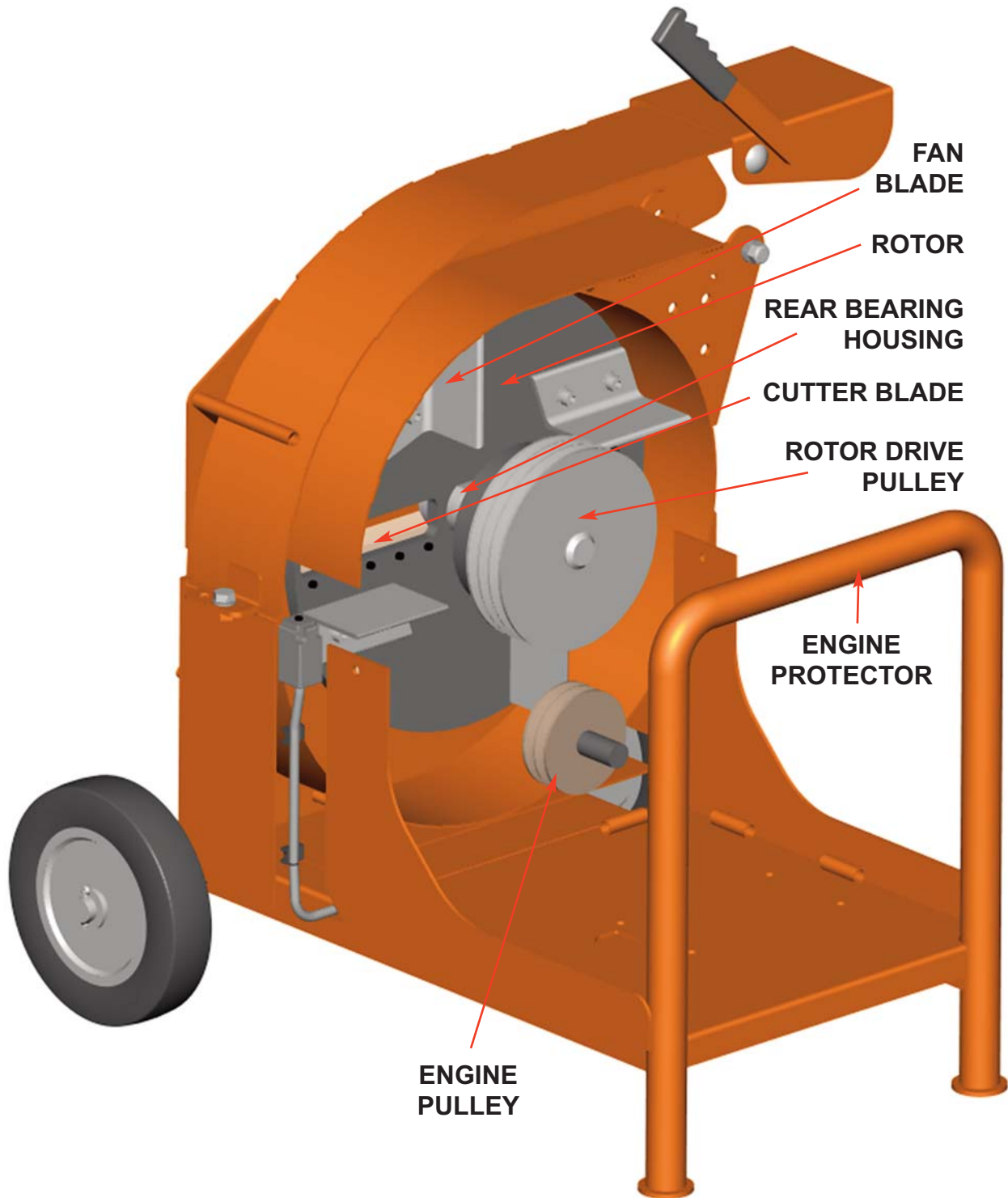



WARNING

The chipper will feed material through on its own. To do this, it relies on sharp blades both on the feed rollers and the chipper rotor. To keep the blades sharp, only feed the machine with clean brushwood. **DO NOT** put muddy/dirty wood, roots, potted plants, bricks, stones or metal into the chipper.



OPERATOR'S PERSONAL PROTECTIVE EQUIPMENT REQUIRED



Chainsaw safety helmet fitted with mesh visor and recommended ear defenders to the appropriate specifications.



Close fitting heavy-duty non-snag clothing.



Work gloves with elasticated wrist.



Face mask if appropriate.



Steel toe cap safety boots.



DO NOT wear rings, bracelets, watches, jewellery or any other items that could be caught in the material and draw you into the chipper.

BASIC WOODCHIPPING SAFETY

The operator should be aware of the following points:

- **MAINTAIN A SAFETY EXCLUSION ZONE** around the chipper of at least 10 metres for the general public or employees without adequate protection. Use hazard tape to identify this working area and keep it clear from debris build up. Chips should be ejected away from any area the general public have access to.
- **HAZARDOUS MATERIAL** - Some species of trees and bushes are poisonous. The chipping action can produce vapour, spray and dust that can irritate the skin. This may lead to respiratory problems or even cause serious poisoning. Check the material to be chipped before you start. Avoid confined spaces and use a facemask if necessary.
- **BE AWARE** when the chipper is processing material that is an awkward shape. The material can move from side to side in the funnel with great force. If the material extends beyond the funnel, the brush may push you to one side causing danger. Badly twisted brush should be trimmed before being chipped to avoid thrashing in the feed funnel.
- **BE AWARE** that the chipper can eject chips out of the feed funnel with considerable force. Always wear full head and face protection.
- **ALWAYS** work on the side of the machine furthest from any local danger, e.g. not road side.



GENERAL SAFETY MATTERS



DO'S AND DON'TS



ALWAYS stop the chipper engine before making any adjustments, refuelling or cleaning.

ALWAYS check rotor has stopped rotating and remove chipper ignition key before maintenance of any kind, or whenever the machine is to be left unattended.

ALWAYS check the machine is well supported and cannot move.

ALWAYS operate the chipper with the engine set to maximum speed when chipping.

ALWAYS check (visually) for fluid leaks.

ALWAYS take regular breaks. Wearing personal protective equipment for long periods can be tiring and hot.

ALWAYS keep hands, feet and clothing out of feed opening, discharge and moving parts.

ALWAYS use the next piece of material or a push stick to push in short pieces. Under no circumstances should you reach into the funnel.

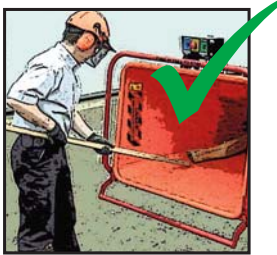

ALWAYS keep the operating area clear of people, animals and children.

ALWAYS keep the operating area clear from debris build up.

ALWAYS keep clear of the chip discharge tube. Foreign objects may be ejected with great force.

ALWAYS ensure protective guarding is in place before commencing work. Failure to do so may result in personal injury or loss of life.

ALWAYS operate the chipper in a well ventilated area - exhaust fumes are dangerous.

DO NOT operate chipper unless available light is sufficient to see clearly.

DO NOT use or attempt to start the chipper without the feed funnel, guards and discharge unit securely in place.

DO NOT stand directly in front of the feed funnel when using the chipper. Stand to one side.

DO NOT allow -



BRICKS STRING CLOTH PLASTIC STONES



METAL GLASS RUBBER ROOTS BEDDING PLANTS

- to enter the machine, as damage is likely.

DO NOT smoke when refuelling.



DO NOT let anyone who has not received instruction operate the machine.

DO NOT climb on the machine at any time.

DO NOT handle material that is partially engaged in the machine.

DO NOT touch any exposed wiring while machine is running.

DO NOT use the chipper inside buildings.



NOISE TEST

MACHINE: TW 13/75G

NOTES: Tested chipping 40mm x 40mm corsican pine 1.5m in length

Noise levels above 80dB (A) will be experienced at the working position. Wear ear protection at all times to prevent possible damage to hearing. All persons within a 4 metre radius must also wear good quality ear protection.

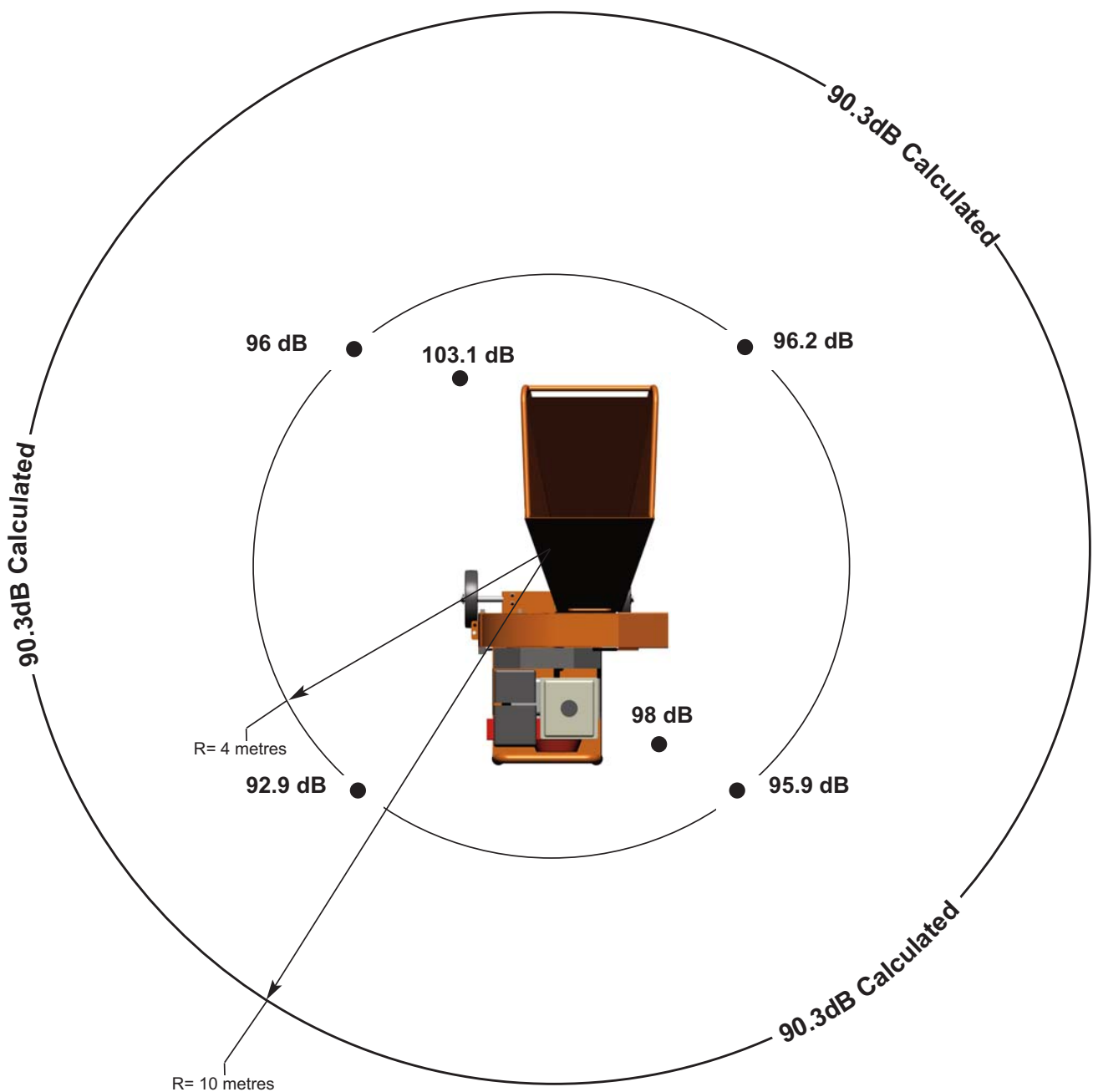

Guaranteed Sound Power: 120dB (A)

As required by Supply of Machinery (safety) regulations of 2008.



SAFE TRANSPORTATION

- THE TW 13/75G chipper may be transported as a unit or with the feed funnel removed.
- TAKE care when loading the TW 13/75G as it is 183 kg in weight.
- STRAP the chipper down firmly before beginning a journey (do not use feed funnel handles to strap down machine).
- ENSURE no debris or water is trapped in the rotor housing that may spill during transit.
- TURN the fuel valve OFF and keep the engine upright.

DELIVERY

All Timberwolf TW 13/75G machines have a full pre - delivery inspection before leaving the factory and are ready to use. Read and understand this instruction manual before attempting to operate the chipper. In particular, read pages 5-7 which contain important health and safety information and advice.

OPERATOR'S PERSONAL PROTECTIVE EQUIPMENT REQUIRED

- CHAINSAW safety helmet fitted with visor and recommended ear defenders to an appropriate specification.
- HEAVY-DUTY gloves with elasticated wrist area.
- CLOSE - FITTING heavy-duty non-snap clothing.
- SAFETY footwear.
- FACE MASK (if appropriate).

See page 5 for more detailed information.

MANUAL CONTROLS

There are five controls on the Honda GX 390 K1 that are required for daily usage of the TW 13/75G chipper.

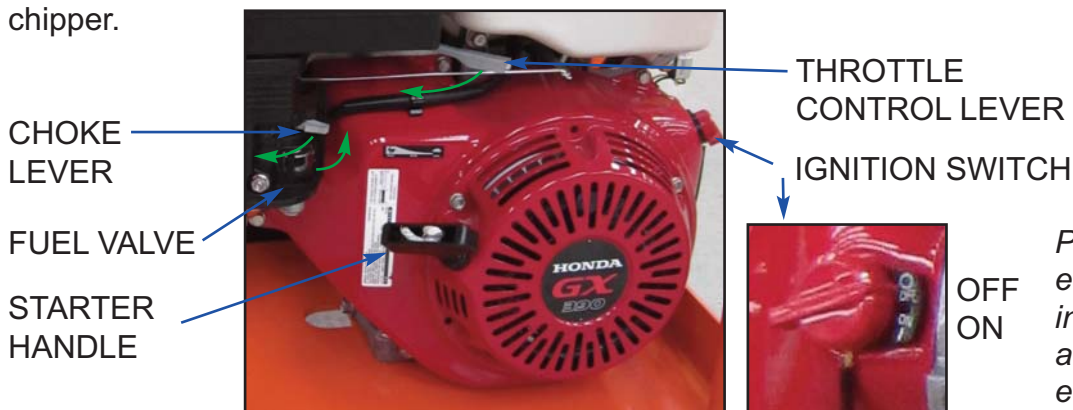

Please refer to the Honda engine manual for detailed instructions of how to start and control the GX390 engine.

STARTING THE ENGINE

- TURN the fuel valve to the 'ON' position.
- MOVE the choke lever to the 'CLOSE' position. NOTE: Do not use the choke if the engine is warm or the air temperature is high.
- MOVE the throttle control lever slightly to the left.
- TURN the ignition switch to the 'ON' position.
- PULL the starter handle lightly until resistance is felt, then pull briskly.
- CAUTION: Do not allow the starter handle to snap back against the engine. Return it gently to prevent damage to the recoil mechanism.
- AS the engine warms up, gradually move the choke lever to the 'OPEN' position.
- POSITION the throttle control lever for the desired engine speed.



STOPPING THE ENGINE

- MOVE the throttle control lever to idle and allow to run for one minute.
- TURN the fuel valve to the 'OFF' position.

EMERGENCY STOPPING

Turn the ignition switch to the 'Off' position (as shown above).

DAILY CHECKS BEFORE STARTING

- LOCATE the machine on firm level ground.
- CHECK engine oil level.
- CHECK the fuel valve is open.
- CHECK all guards are in place.
- CHECK the discharge unit is pointing in a safe direction.
- CHECK the feed funnel to ensure no objects are inside.

For parts location see diagrams on pages 3 & 4.

STARTING TO CHIP

WARNING

Do not use or attempt to start the chipper without the protective guarding and discharge unit securely in place. Failure to do so may result in personal injury or loss of life.



- CHECK that the chipper is running smoothly.
- STAND to one side of the feed funnel.
- PROCEED to feed material into the feed funnel.

CHIPPING

Wood up to 75 mm in diameter can be fed into the feed funnel. Enter it into the funnel butt end first. Release the material before it engages the rotor. Some pieces of wood may move around significantly whilst being chipped.

The wood will be drawn into the cutting blade quite quickly, be ready for this to happen. Stand well clear.

A piece of wood which is too tough or too large for the chipper will slow the engine down. When this happens it is possible to hold back the branches that are being chipped and allow the engine to regain its speed again.

If a piece of wood gets stuck in the funnel and it cannot be chipped due to its size or shape, it will need to be removed. Trim the branch until it is a suitable shape for the chipper to accept.



BLADE WEAR

The most important part of using a wood chipper is keeping the cutter blades sharp. Timberwolf chipper blades are hollow ground to an angle of 40 degrees. When performing daily blade checks ensure blade edge is sharp and free from chips, if there is any evidence of damage, or the edge is "dull" change the blade(s). The TW 13/75G is fitted with one blade 177 mm (7") long. It is 43 mm wide when new. A new blade should chip for up to 25 hours before it requires sharpening. This figure will be drastically reduced by feeding the machine with stony, sandy or muddy material.

As the blade becomes blunt performance is reduced, with increased stress and load on the machine the chips will become more irregular and stringy. At this point the blade should be sent to a reputable blade sharpening company. The blade can be sharpened several times in its life. A wear mark on the reverse side indicates the safe limit of blade wear. Replace when this line is exceeded.

The machine is also fitted with a static blade (anvil). It is important that the anvil is in good condition to allow the cutting blades to function efficiently. Performance will be poor, even with sharp cutter blades, if the anvil is worn.

BLOCKAGES

Always be aware that what you are putting into the chipper must come out. If the chips stop coming out of the discharge tube but the chipper is taking material in - STOP IMMEDIATELY. Continuing to feed material into a blocked machine may cause damage and will make it difficult to clear.

If the chipper becomes blocked, proceed as follows:

- STOP the engine, as per instructions on page 9.
- REMOVE the M12 screw that retains the top rotor housing.
- OPEN the top rotor housing.
- WEARING gloves, reach into the rotor housing and scoop out the debris causing the blockage.

WARNING

Do not reach into the rotor housing with unprotected hands. There are sharp blades and any small movement of the rotor may cause serious injury.



- IT is not necessary to remove all the debris, just the majority.
- CLOSE the rotor housing and clamp down tightly.
- RESTART the engine and increase to full speed.
- ALLOW chipper time to clear the rotor housing.
- FEED a small piece of wood in to ensure complete clearance.

NOTE

Continuing to feed the chipper with brushwood once it has become blocked will cause the chipper to compact the chips in the rotor housing and it will be difficult and time consuming to clear.

AVOID THIS SITUATION - WATCH THE DISCHARGE TUBE AT ALL TIMES.



**THE FOLLOWING PAGES DETAIL ONLY
BASIC MAINTENANCE GUIDELINES SPECIFIC
TO YOUR CHIPPER.**



THIS IS NOT A WORKSHOP MANUAL.

THE FOLLOWING GUIDELINES ARE NOT EXHAUSTIVE AND DO NOT EXTEND TO GENERALLY ACCEPTED STANDARDS OF ENGINEERING/MECHANICAL MAINTENANCE THAT SHOULD BE APPLIED TO ANY PIECE OF MECHANICAL EQUIPMENT AND THE CHASSIS TO WHICH IT IS MOUNTED.

AUTHORISED TIMBERWOLF SERVICE AGENTS ARE FULLY TRAINED IN ALL ASPECTS OF TOTAL SERVICE AND MAINTENANCE OF TIMBERWOLF WOOD CHIPPERS. YOU ARE STRONGLY ADVISED TO TAKE YOUR CHIPPER TO AN AUTHORISED AGENT FOR ALL BUT THE MOST ROUTINE MAINTENANCE AND CHECKS.

TIMBERWOLF ACCEPTS NO RESPONSIBILITY FOR THE FAILURE OF THE OWNER/USER OF TIMBERWOLF CHIPPERS TO RECOGNISE GENERALLY ACCEPTED STANDARDS OF ENGINEERING/MECHANICAL MAINTENANCE AND APPLY THEM THROUGHOUT THE MACHINE.

**THE FAILURE TO APPLY GENERALLY ACCEPTED
STANDARDS OF MAINTENANCE, OR THE PERFORMANCE OF
INAPPROPRIATE MAINTENANCE, MAY INVALIDATE
WARRANTY IN WHOLE OR IN PART.**

**PLEASE REFER TO YOUR AUTHORISED
TIMBERWOLF SERVICE AGENT FOR
SERVICE AND MAINTENANCE.**





SERVICE SCHEDULE

WARNING

Always immobilise the machine by stopping the engine, removing the ignition key and disconnecting the battery before undertaking any maintenance work.



| SERVICE SCHEDULE | Daily Check | 25 Hours | 50 Hours | 500 Hours |
|--|-------------|--|----------|-----------|
| Check engine oil - top up if necessary (10W-30). | ✓ | | | |
| Check for engine oil leaks. | ✓ | | | |
| Check fuel level. | ✓ | | | |
| Check feed funnel and belt guard are securely fitted. | ✓ | | | |
| Clean engine air intake. | ✓ | | | |
| Check air filter element. | ✓ | | | |
| Check blade condition. | ✓ | | | |
| Check for tightness all nuts, bolts and fastenings making sure nothing has worked loose. | | ✓ | | |
| Check tension of main drive belts (and tension if necessary). | | ✓ | | |
| Check cutting anvil. | | | ✓ | |
| Grease front rotor bearing. | | | ✓ | |
| Check for loose electrical wiring. | | | | ✓ |
| Renew oil filter. | } | REFER TO YOUR ENGINE SUPPLIERS MANUAL | | |
| Replace spark plugs. | | | | |
| Check valve clearances. | | | | |
| Clean air filter. | | | | |
| Clean sediment cup. | | | | |
| Clean fuel tank and strainer. | | | | |
| Check fuel line. | | | | |

NOTE: Your Timberwolf woodchipper is covered by a full 12 months parts and labour warranty. Subject to correct maintenance and proper machine usage, the bearings are guaranteed for 12 months regardless of hours worked by the machine. In conditions of 'heavy usage' - i.e. in excess of 500 hours per year - it is recommended that the bearings are changed annually to ensure that the machine retains optimum working performance.



SAFE MAINTENANCE

ALWAYS IMMOBILISE THE ENGINE BEFORE UNDERTAKING ANY MAINTENANCE WORK ON THE CHIPPER BY REMOVING THE KEY AND DISCONNECTING THE BATTERY.

- HANDLE blades with extreme caution to avoid injury. Gloves should always be worn when handling the cutter blades.
- THE drive belts should be connected while changing blades, as this will restrict sudden movement of the rotor.
- THE major components of this machine are heavy. Lifting equipment must be used for disassembly.
- CLEAN machines are safer and easier to service.

SAFE LIFTING OF THE CHIPPER

The lifting eye is designed to lift the machine's weight only. Do not use hoist hook directly on the lifting eye, use a correctly rated safety shackle. Inspect the lifting eye prior to each use - **DO NOT USE LIFTING EYE IF DAMAGED.**

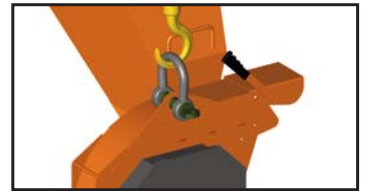

SPARES

Only fit genuine Timberwolf replacement blades, screws and chipper spares. Failure to do so will result in the invalidation of the warranty and may result in damage to the chipper, personal injury or even loss of life.

COPPER EASE SAFETY INFORMATION

Product name: Copper Ease.

Copper Ease contains no hazardous ingredients at or above regulatory disclosure limits, however, safety precautions should be taken when handling (use of oil-resistant gloves and safety glasses are recommended - respiratory protection is not required). Avoid direct contact with the substance and store in a cool, well ventilated area avoiding sources of ignition, strong oxidising agents and strong acids. Dispose of as normal industrial waste (be aware of the possible existence of regional or national regulations regarding disposal), do not discharge into drains or rivers.

In case of fire: in combustion the product emits toxic fumes, extinguish with alcohol or polymer foam, carbon dioxide or dry chemical powder. Wear self-contained breathing apparatus and protective clothing to prevent contact with skin and eyes.

FIRST AID

Skin contact: there may be mild irritation at the site of contact, wash immediately with plenty of soap and water.

Eye contact: there may be irritation and redness, bathe the eye with running water for 15 minutes.

Ingestion: there may be irritation of the throat, do not induce vomiting, wash out mouth with water.

A safety data sheet for this product can be obtained by writing to the manufacturer at the following address: Comma Oil and Chemicals Ltd., Deering Way, Gravesend, Kent DA12 2QX. Tel: 01474 564311, Fax: 01474 333000.

ENGINE SERVICING

All engine servicing must be performed in accordance with the Engine Manufacturer's handbook provided with the machine. **FAILURE TO ADHERE TO THIS MAY INVALIDATE WARRANTY AND/OR SHORTEN THE LIFE OF THE ENGINE.**



CHANGE BLADES

WARNING

Wear riggers gloves for the blade changing operation.

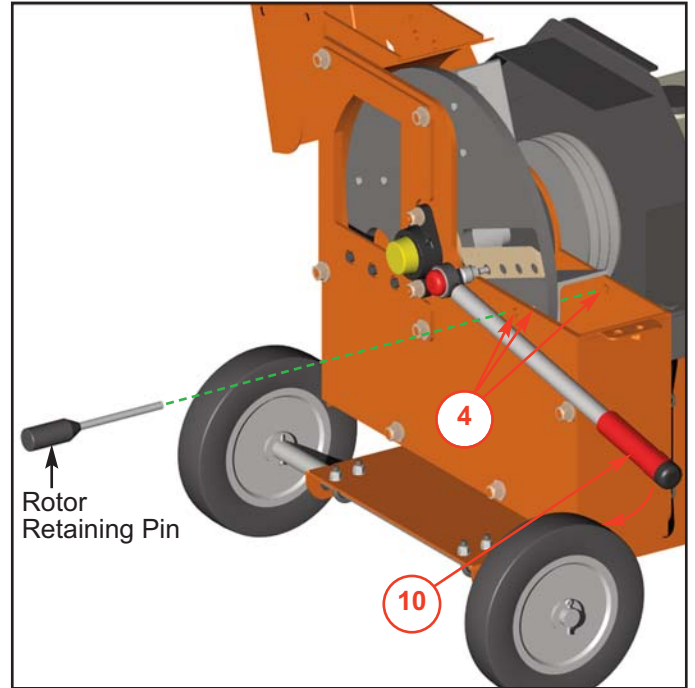
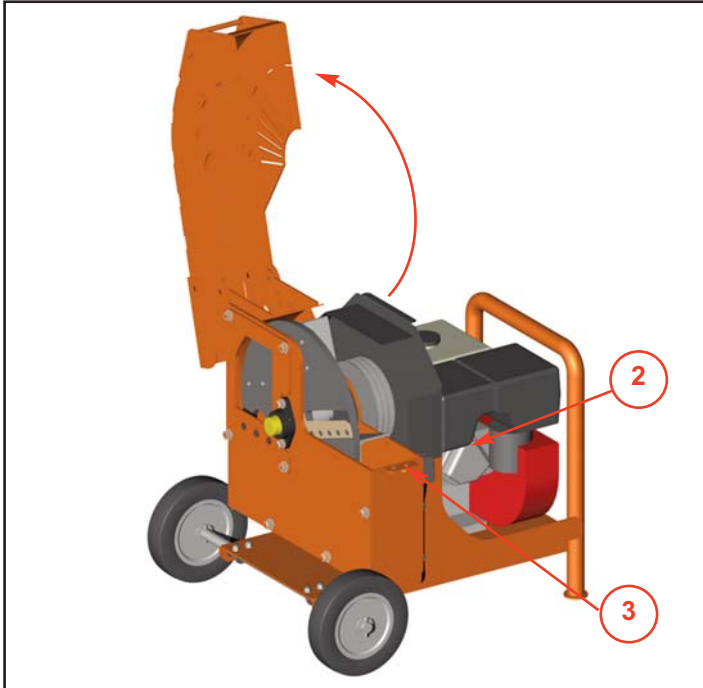

1. Turn engine off, as per instructions on page 9.
2. Pull the plug cap from the spark plug.
3. Remove the M12 screw that retains the top rotor housing using a 19 mm spanner.
4. Turn the rotor by hand using the fan blades so that holes (4) are aligned and insert the 2496F Rotor Retaining Pin (supplied in tool kit).
5. Use a small screw driver to clean out the star socket screws heads retaining the blade.
6. Undo blade screws using the star socket provided.
7. **Before fitting replacement blades ensure the blade seat is clean. No material should be allowed to sit between the blade and the rotor.**
8. Check screws being replaced are not damaged. If so, these should be renewed.
9. Apply a thin layer of copper grease to the entire screw thread.
10. **Retighten the screws to 29Nm (22lb/ft)**
This torque setting is vitally important to ensure your bolts come out at a later date. Timberwolf recommend you purchase a torque wrench for this and other jobs on the chipper.
11. Remove Rotor Retaining Pin.
12. Close rotor housing and replace retaining screw.
13. Refit spark plug cap to spark plug.

WARNING



Always sharpen blades on a regular basis. Failure to do so will cause the machine to under perform and will overload engine and bearings causing machine breakdown. Blades must not be sharpened beyond the wear mark (see diagram). Failure to comply with this could result in machine damage, injury or loss of life.

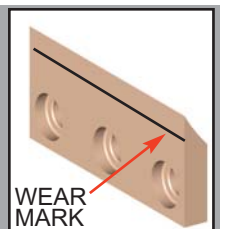



CHECK FITTINGS

The Timberwolf TW 13/75G is subject to large vibrations during the normal course of operation. Consequently there is always a possibility that nuts and bolts will work themselves loose. It is important that periodic checks are made to ensure the security of all fasteners. Fasteners should be tightened using a torque wrench to the required torque (see below). **Uncalibrated torque wrenches can be inaccurate by as much as 25%. It is therefore essential that a calibrated torque wrench is used to achieve the tightening torques listed below.**

| | Size | Pitch | Head | Torque lbft | Torque Nm |
|-----------------------|------|----------|-----------|-------------|-----------|
| Rotor Housing Clamp | M12 | Standard | 19 mm Hex | 60 | 80 |
| Blade Bolts | M8 | Standard | T40 Torq | 22 | 29 |
| Funnel Retaining Nuts | M12 | Standard | 19 mm Hex | 60 | 80 |
| General | M8 | Standard | 13 mm Hex | 17 | 23 |
| General | M10 | Standard | 17 mm Hex | 34 | 46 |
| General | M12 | Standard | 19 mm Hex | 60 | 80 |

TENSION BELTS

NOTE: There will normally be a rapid drop in tension during run-in period for new belts. When new belts are fitted, check the tension every 2 - 3 hours and adjust until the tension remains constant.

Belt failures due to lack of correct tensioning will not be covered under your Timberwolf warranty.

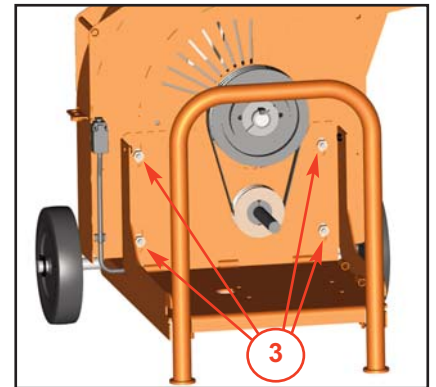
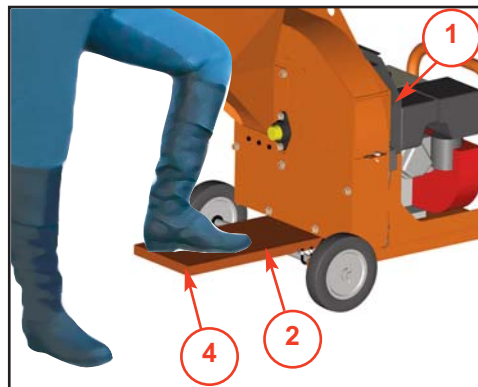

1. Remove the belt guard.
2. Insert a piece of wood approximately 25mm x 150mm x 1200mm (1"x 6"x 48") in the gap as shown.
3. Loosen the four Nyloc nuts located behind the engine.
4. With the chipper firmly supported use the piece of wood to lever the rotor housing upwards.
5. For instructions on checking belt tension & correct belt tension values, please refer to the Timberwolf V-Belt Tensioning Data Table (pg 27).
6. As the belts become taught retighten the four Nyloc nuts.
7. Replace the belt guard.
8. Remove the piece of wood.

GREASING ROTOR BEARINGS

1. Remove rubber cap from front bearing housing grease nipple.
2. Apply 1 pump of grease to bearing.
3. Replace cap.

ANVIL CHANGING

The anvil is an important component in maintaining a consistent machine performance. Inspect it through an open rotor housing. A measure of the wear is how sharp the edge is. If it has become seriously rounded then it is appropriate to change it.

Turning or replacing the anvil should be carried out by a Timberwolf dealer.



ENVIRONMENTAL MANUFACTURING LLP 12 MONTH CHIPPER WARRANTY

WARRANTY PERIOD

The warranty period for the woodchipper commences on the date of sale to the first end user and continues for a period of 12 months. This guarantee is to the first end user only and is not transferable except when an authorised Timberwolf Dealer has a woodchipper registered with Environmental Manufacturing LLP as a hire chipper or long term demonstrator – in these situations they are duly authorised to transfer any remaining warranty period to their first end user. Any warranty offered by the Timberwolf Dealer beyond the original 12 month period will be wholly covered by said Dealer.

LIABILITY

Our obligation under this warranty is limited to repair at Environmental Manufacturing LLP premises or at our option an Environmental Manufacturing LLP approved Timberwolf dealer. No liability will be accepted for special, indirect, incidental, or consequential loss or damages of any kind.

WARRANTY STATEMENT

Environmental Manufacturing LLP warrants to the first end user that;

- Your woodchipper shall be designed, built and equipped, at the point of sale, to meet all current applicable regulations.
- Your chipper shall be free from manufacturing defects both in materials and workmanship in normal service for the period mentioned above.

Warranty will not apply to a failure where normal use has exhausted the life of a component.

Engine units are covered independently by their respective manufacturer warranties.

OWNERS WARRANTY RESPONSIBILITIES

As the owner of an Environmental Manufacturing LLP woodchipper you are responsible for the following;

- Operation of the woodchipper in accordance with the Environmental Manufacturing LLP instruction manual.
- Performance of the required maintenance listed in your Environmental Manufacturing LLP instruction manual.
- In the event of a failure the Environmental Manufacturing LLP authorised Timberwolf dealer is to be notified within 10 days of failure and the equipment is to be made available for unmolested inspection by the dealer technician.

WARRANTY RESTRICTIONS

The Environmental Manufacturing LLP warranty is restricted to the first end user only and is not transferable except when an authorised Timberwolf Dealer has a woodchipper registered with Environmental Manufacturing LLP as a hire chipper or long term demonstrator – in these situations they are duly authorised to transfer any remaining warranty period to their first end user.

The Environmental Manufacturing LLP warranty may be invalidated if any of the following apply;

- The failed parts or assembly is interfered with in any way.
- Normal maintenance has not been performed.
- Incorrect reassembly of components.
- The machine has undergone modifications not approved in writing by Environmental Manufacturing LLP.
- In the case of tractor driven equipment, use has been on an unapproved tractor.
- Conditions of use can be deemed abnormal.
- The machine has been used to perform tasks contrary to those stated in the Environmental Manufacturing LLP instruction manual.

WARRANTY SERVICE

To obtain warranty service please contact your nearest Environmental Manufacturing LLP approved Timberwolf dealer. To obtain details of the nearest facility please contact Environmental Manufacturing LLP at the address on the front of this manual.

These warranty terms are in addition to and not in substitution for and do not affect any right and remedies which an owner might have under statute or at common law against the seller of the goods under the contract by which the owner acquired the goods.



CERTIFICATE OF CONFORMITY

Environmental Manufacturing LLP

Entec House,
Tomo Industrial Estate,
Stowmarket,
Suffolk IP14 5AY

Tel: 01449 765800 Fax: 01449 765801

E C Declaration of Conformity



Environmental Manufacturing LLP as the designer and manufacturer, certifies that the machine stipulated below complies with all the relevant provisions of the:

Machinery Directive; 2006/42/EC
(& other relevant directives)

and the National Laws and Regulations adopting these directives.

| | | |
|---------------------------------|---|---|
| Designer/Manufacturer | : | Environmental Manufacturing LLP |
| Description of Machinery | : | Self-powered portable machine intended to chip up tree waste prior to disposal. |
| Model | : | TW 13/75G |
| Serial No. | : | <u>Serial Manufacture</u> |

BSI Transposed Harmonised Standards applied: (including parts/clauses of):

BS EN 12100-1: 2003 Safety of Machinery- Basic concepts, BS EN 13857-1: 2008 Safety of Machinery-Safety distances to danger zones, BS EN 60204-1: 1998 Safe electrical practices, BS EN 13732-1:2006 Safety of Machinery – Temperatures of touchable surfaces, BS EN 13849-1: 2008 – Safety of Machinery – Safety related parts of control systems, BS EN 982: 1996 – Safety of Machinery – Hydraulics, BS EN 1088: 1995 – Safety of Machinery – Interlocking devices, BS EN 13525: 2005 – Forestry Machinery – Wood chippers – Safety.

“Responsible” Person empowered to sign:  Mr. Jeff Haines
Position in Company: Technical Director

Date: 1st December 2009



ENVIRONMENTAL
MANUFACTURING LLP
STOWMARKET,
SUFFOLK IP14 5AY UK



MODEL

SERIAL NO.

CARR.
TYP/SN.

GROSS
WEIGHT

NOM.
POWER

DATE

EXAMPLE

19 DECALS



**TIMBERWOLF
TW 13/75G**



616



617



670



671



1363



1522

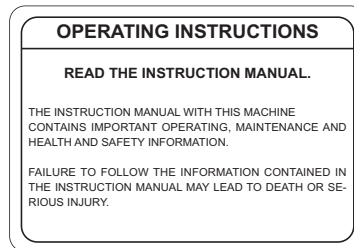

1662

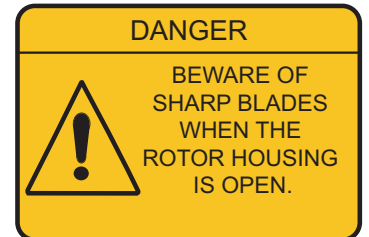

2944



2948

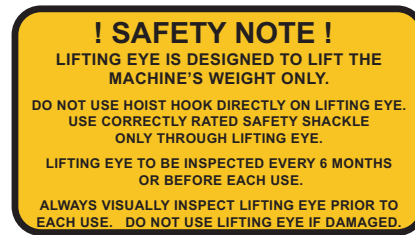

2949

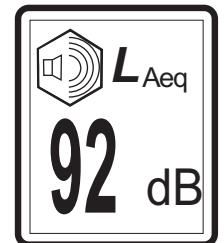

3004

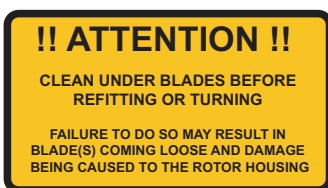

3022



4099 X 2



17290



17294

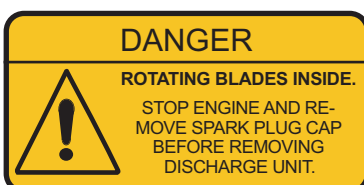

18322











18393

**TIMBERWOLF
TW 13/75G**

P*155



671 - these individual decals are supplied as a set, they may not all apply to your machine.

| | | |
|--|--|--|
| <p>DANGER</p>  <p>DO NOT OPERATE WITHOUT THIS COVER IN PLACE</p> | <p>DANGER</p>  <p>AUTOFEED SYSTEM FITTED. ROLLERS MAY TURN WITHOUT WARNING! WHEN ENGINE IS SWITCHED OFF THE ROLLERS WILL TURN DURING THE RUN DOWN PERIOD</p> | <p>CAUTION</p> <p>WHEN TRANSPORTING DISCHARGE CLAMPS MAY WORK LOOSE. CHECK FREQUENTLY</p> |
| <p>DANGER</p>  <p>DO NOT OPERATE WITHOUT THIS COVER IN PLACE</p> | <p>FUEL HERE </p> <p>RISK OF FIRE</p> <p>ALLOW ENGINE TO COOL FOR 1 MINUTE BEFORE REFUELLING. USE UNLEADED PETROL</p> | <p>CAUTION</p> <p>AVOID STANDING DIRECTLY IN FRONT OF FEED FUNNEL TO REDUCE EXPOSURE TO NOISE, DUST AND RISK FROM EJECTED PARTICLES</p> |
| <p>DANGER</p>  <p>DO NOT OPERATE WITHOUT THIS COVER IN PLACE</p> | <p>CAUTION</p> <p>DO NOT PUT ROAD SWEEPINGS IN MACHINE AS GRIT WILL DAMAGE BLADES</p> | <p>DANGER</p>  <p>ROTATING BLADES</p> |
| <p>DANGER</p>  <p>DO NOT OPERATE WITHOUT THIS COVER IN PLACE</p> | <p>DANGER</p>  <p>STOP ENGINE AND REMOVE KEY BEFORE REMOVING DISCHARGE UNIT. ROTATING BLADES INSIDE.</p> | <p>DANGER</p>  <p>DO NOT USE THIS MACHINE WITHOUT THE DISCHARGE UNIT FITTED FAILURE TO COMPLY MAY RESULT IN SERIOUS INJURY OR DAMAGE</p> |

(Blank)



PARTS LISTS

The following illustrations are for parts identification only. The removal or fitting of these parts may cause a hazard and should only be carried out by trained personnel.

| | <i>Page No.</i> |
|---------------------------------|--------------------|
| CHASSIS / ROTOR HOUSING | 23 |
| DECALS | 19 & 20 |
| ENGINE | 24 |
| FUNNEL / DISCHARGE | 25 |
| ROTOR | 26 |
| V- BELT TENSIONING TABLE | 27 |

23 CHASSIS/ROTOR HOUSING



TIMBERWOLF
TW 13/75G

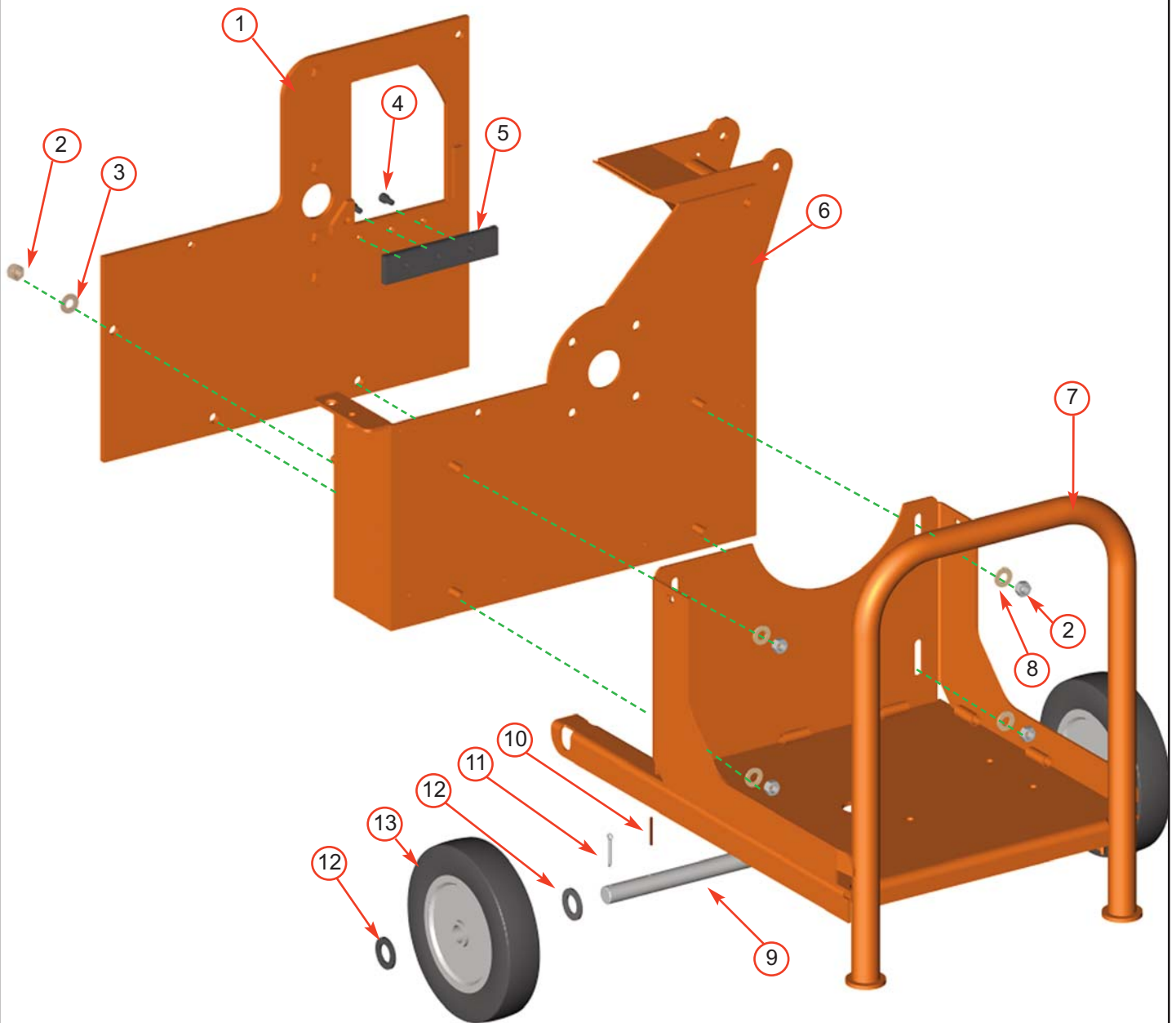

| Item | Part No | Part Name | Q'ty |
|------|---------|--------------------|------|
| 1 | 1567FO | Front Plate | 1 |
| 2 | 0644 | M12 P Nyloc Nut | 4 |
| 3 | 0702 | M12 A Washer | 3 |
| 4 | 0345 | Capheads | 3 |
| 5 | 0105MH | Gravity Anvil | 1 |
| 6 | 18452FO | Main Rotor Housing | 1 |
| 7 | 2475FO | Chassis | 1 |
| 8 | 0704 | M12 C Washer | 4 |
| 9 | 2476MS | Axle | 1 |
| 10 | 0068M | Roll Pin | 4 |
| 11 | 0528 | Split Pin | 2 |
| 12 | 0707 | M24 A Washer | 4 |
| 13 | 2478 | Wheel | 2 |

Date Last Modified: 24th Jan 08

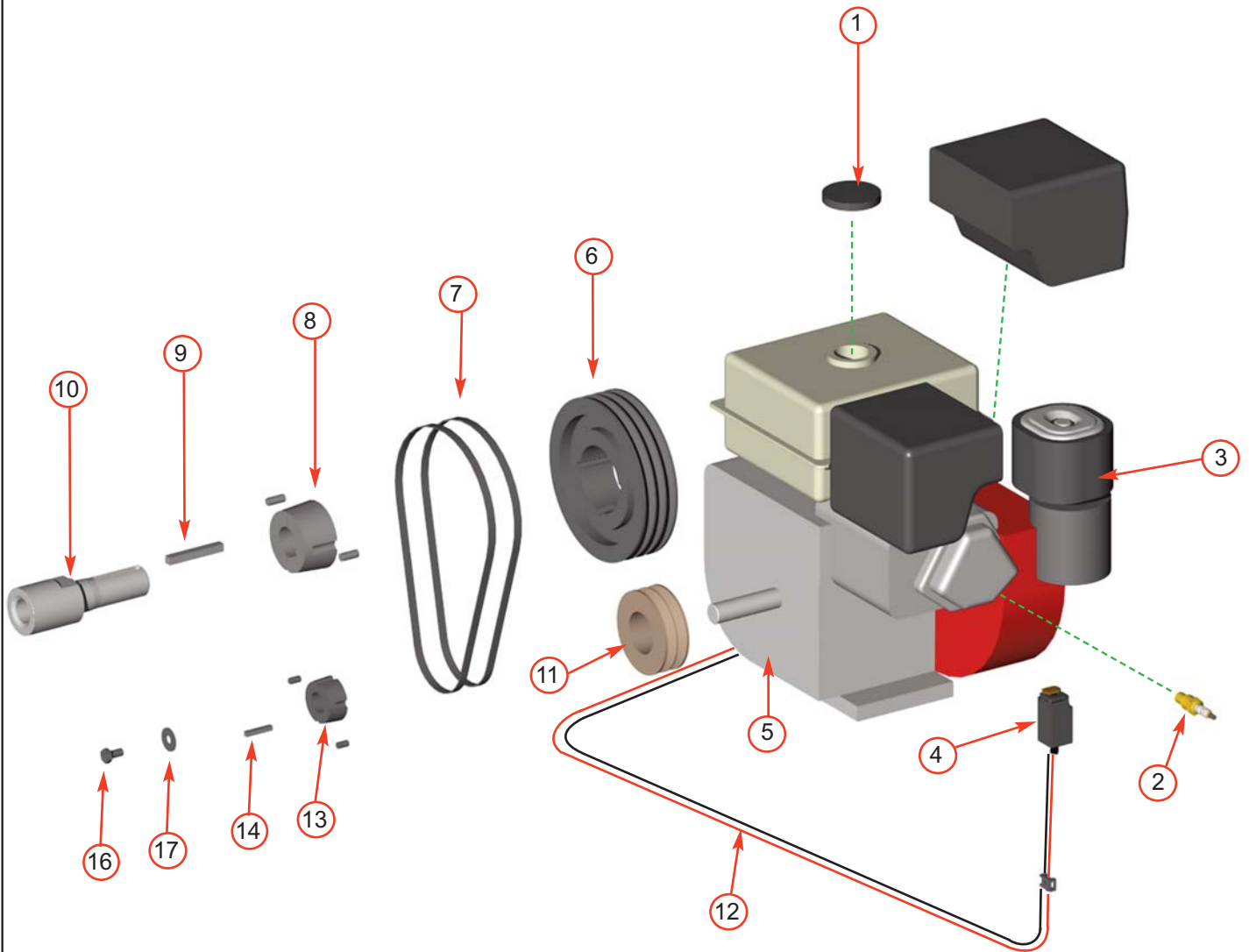

Date Last Modified: 5th Oct 2012

| Item | Part No | Part Name | Q'ty | Item | Part No | Part Name | Q'ty |
|------|--------------------|------------------|------|------|---------|------------------------|------|
| 1 | supp'd with engine | Fuel Cap | 1 | 9 | 18960M | Rotor Shaft Key | 1 |
| 2 | supp'd with engine | Spark Plug | 1 | 10 | 4280M | Rear Shaft | 1 |
| 3 | supp'd with engine | Air Filter | 1 | 11 | 1135 | Pulley 118-2 SPA | 1 |
| 4 | 1348 | Safety Switch | 1 | 12 | 2494 | Stop Loom | 1 |
| 5 | 1172 | Honda Engine | 1 | 13 | 0405 | Bush 1610 x 1" | 1 |
| 6 | 1351 | Pulley 200-3 SPA | 1 | 14 | 0061 | Engine Shaft Key | 1 |
| 7 | 1533 | Belt 900 XPA 2 | 2 | 16 | 17283 | Long Socket Head Screw | 1 |
| 8 | 0410 | Bush 2517 x 38mm | 1 | 17 | 4344 | M10/30 Washer | 1 |

25 FUNNEL/DISCHARGE



TIMBERWOLF
TW 13/75G

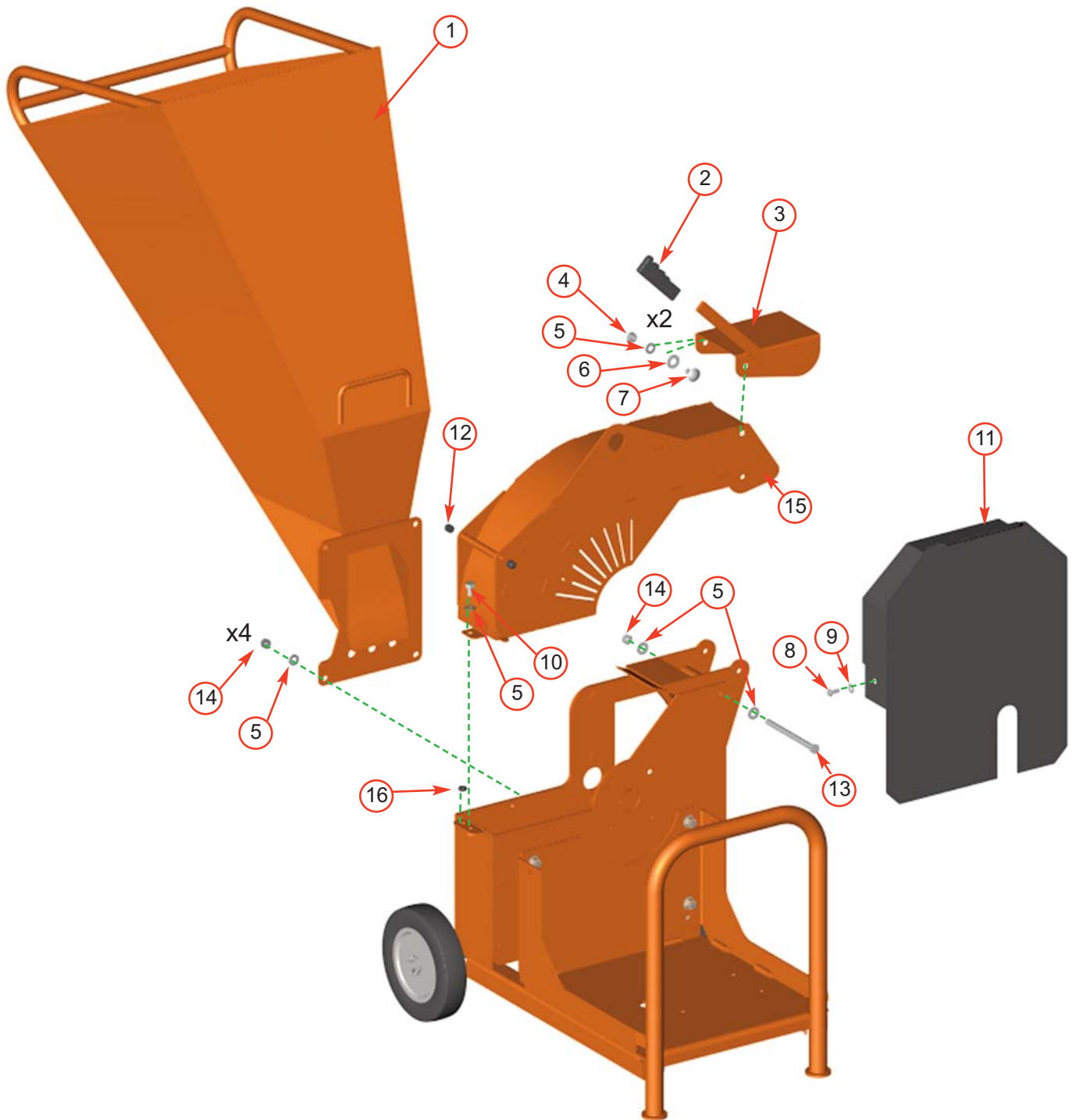

Date Last Modified: 24th Jan 08

| Item | Part No | Part Name | Q'ty | Item | Part No | Part Name | Q'ty |
|------|---------|-------------------|------|------|---------|--------------------|------|
| 1 | 1642FO | Funnel | 1 | 9 | 0712 | M8 C Washer | 2 |
| 2 | 0134 | Plastic Grip | 1 | 10 | 0318 | M12/20 Bolt | 1 |
| 3 | 1052FO | Discharge Bucket | 1 | 11 | 2000FB | Belt Guard | 1 |
| 4 | 0045 | M12 T Nyloc Nut | 2 | 12 | 2493 | 13 mm Plastic Plug | 2 |
| 5 | 0702 | M12 A Washer | 11 | 13 | 17336 | M12/170 Bolt | 1 |
| 6 | 1143 | M16 A Washer | 2 | 14 | 0046 | M12 Plain Nut | 5 |
| 7 | 0320 | M12/25 Cup Square | 2 | 15 | 18453FO | Discharge | 1 |
| 8 | 0346 | M8/20 Bolt | 2 | 16 | 0654 | Rubber Grommet | 1 |

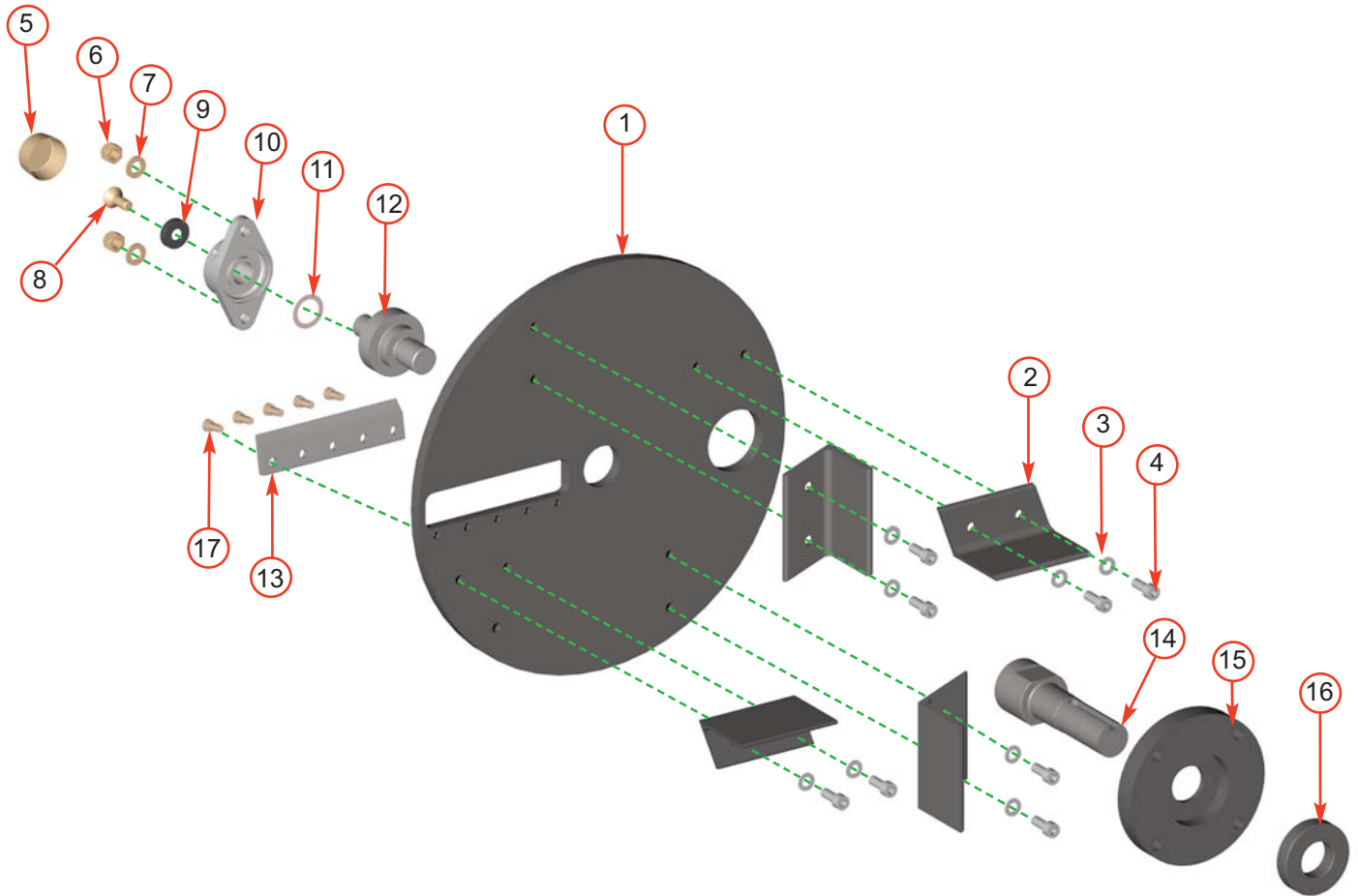

Date Last Modified: 10th Sept 09

| Item | Part No | Part Name | Q'ty | Item | Part No | Part Name | Q'ty |
|------|---------|-----------------------|------|------|---------|----------------------|----------|
| 1 | 17342M | Rotor | 1 | 10 | 0648 | Bearing Front SFT25 | 1 |
| 2 | 17317F | Fan Blade | 4 | 11 | 0796 | 20 thou Shim | As Req'd |
| 3 | 0701 | M10 A Washer | 8 | 12 | 1061M | Nose Shaft | 1 |
| 4 | 0305 | M10/25 Caphead | 8 | 13 | 071MH | Blade | 1 |
| 5 | 0633 | Bearing Cap | 1 | 14 | 18948M | Rear Shaft | 1 |
| 6 | 0644 | M12 P Nyloc Nut | 2 | 15 | 4063MCB | Bearing Housing Rear | 1 |
| 7 | 0702 | M12 A Washer | 2 | 16 | 0495 | Bearing | 1 |
| 8 | 0428 | M12/30 C'sunk Patched | 1 | 17 | 0065 | M8/20 Blade Bolt | 5 |
| 9 | 0713 | Heavy C'sunk Washer | 1 | | | | |



TIMBERWOLF V-BELT TENSIONING DATA TABLE

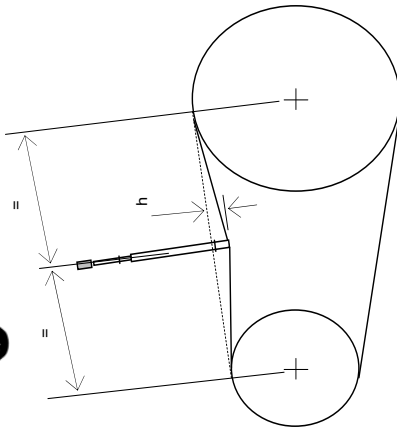

METHOD:

1. SET THE DEFLECTION DISTANCE ON THE LOWER SCALE OF THE TENSION GAUGE SO THAT THE UNDERSIDE OF THE 'O'-RING EQUALS THE 'h' VALUE GIVEN IN THE TABLE BELOW
2. ENSURE THAT THE DEFLECTION FORCE SCALE IS ZERO'D BY PUSHING THE UPPER 'O'-RING ALL THE WAY DOWN
3. PLACE THE TENSION GAUGE IN THE CENTRE OF THE BELT SPAN AS SHOWN IN THE DIAGRAM LEFT
4. PRESS DOWNWARDS ON THE RUBBER BUFFER, DEFLECTING THE BELT UNTIL THE UNDERSIDE OF THE LOWER 'O'-RING IS LEVEL WITH THE BELT BEHIND (USE A STRAIGHT EDGE IF THERE IS ONLY 1 BELT)
5. TAKE THE READING FROM THE DEFLECTION SCALE OF THE TENSION METER (READ AT THE LOWER EDGE OF THE 'O'-RING) & COMPARE THIS VALUE WITH THAT GIVEN IN THE TABLE BELOW
6. TIGHTEN OR LOOSEN BELTS AS REQUIRED FOLLOWING PROCEDURE GIVEN IN THE OPERATOR'S MANUAL

TENSION GAUGES ARE AVAILABLE FROM TIMBERWOLF SPARES, QUOTING PART No. 18091

TIPS ON BELT TIGHTENING:

- A) THERE WILL NORMALLY BE A RAPID DROP IN TENSION DURING THE RUN-IN PERIOD FOR NEW BELTS. WHEN NEW BELTS ARE FITTED, CHECK THE TENSION EVERY 2-3 HOURS & ADJUST UNTIL THE TENSION REMAINS CONSTANT
- B) THE BEST TENSION FOR V-BELT DRIVES IS THE LOWEST TENSION AT WHICH THE BELTS DO NOT SLIP OR RATCHET UNDER THE HIGHEST LOAD CONDITION
- C) TOO MUCH TENSION SHORTENS BELT & BEARING LIFE
- D) TOO LITTLE TENSION WILL AFFECT THE PERFORMANCE OF YOUR MACHINE ESPECIALLY IN RESPECT OF NO-STRESS DEVICES
- E) ENSURE THAT BELT DRIVES ARE KEPT FREE OF ANY FOREIGN MATERIALS
- F) IF A BELT SLIPS - TIGHTEN IT!

| TW MODEL No.: | | 13/75G | 18/100G | 125PH | 150DHB | 150VTR | 190TDHB | 190TFTFR 190TVGTR | 350DHB(f) | PTO100 | PTO150 | S426 SHREDDER | S426TFTFR SHREDDER | PTO S426 SHREDDER | SX200PHB(c) |
|---------------|---------------------|--------------------------|--------------------------|--------------------------|--------------------------|--------------------------|--------------------------|--------------------------|--------------------------|--------------------------|--------------------------|--------------------------|--------------------------|--------------------------|--------------------------|
| Rotor Belts | Belt Mfr / Type | Gates Super HC-MN SPA | Gates Super HC-MN SPA | Gates Super HC-MN SPA | Gates Super HC-MN SPA | Gates Super HC-MN SPA | Gates Super HC-MN SPA | Gates Super HC-MN SPA | Gates Super HC-MN SPA | Gates Super HC-MN SPA | Gates Super HC-MN SPA | Gates Super HC-MN SPA | Gates Super HC-MN SPA | Gates Super HC-MN SPA | Gates Super HC-MN SPA |
| | Belt Length | 900.0 | 1060.0 | 1060.0 | 1060.0 | 1060.0 | 1232.0 | 1232.0 | 2530.0 | 900.0 | 900.0 | 2120.0 | 2120.0 | 1700.0 | 1272.0 |
| | Belt deflection | h 4.0 | 3.5 4.0 | 4.0 4.0 | 4.0 4.0 | 4.0 4.0 | 4.0 4.0 | 4.0 4.0 | 8.0 8.0 | 4.0 4.0 | 4.0 4.0 | 8.0 8.0 | 8.0 8.0 | 6.0 6.0 | 5.0 5.0 |
| Pump Belt | Force reading (Kgf) | New belt 3.4 - 3.6 | 3.1 - 3.3 | 3.3 - 3.6 | 4.3 - 4.5 | 4.3 - 4.5 | 3.9 - 4.1 | 3.9 - 4.1 | 3.3 - 3.6 | 3.3 - 3.5 | 3.8 - 4.0 | 3.3 - 3.5* | 3.3 - 3.5 | 6.5 - 6.9 | 1.9 - 2.1 |
| | Belt Mfr / Type | N/A | N/A | Gates Super HC-MN SPA | N/A | Gates Super HC-MN SPA | N/A | Gates Super HC-MN SPA | N/A | N/A | Gates Super HC-MN SPA | N/A | Gates Super HC-MN SPA | N/A | Gates Super HC-MN SPA |
| | Belt Length | | | 925.0 | | 900.0 | | 925.0 | | | | | 1060.0 | | 950.0 |
| Rotor Belts | Belt deflection | h 4.0 | 4.0 | 4.0 | 4.0 | 4.0 | 4.0 | 4.0 | 8.0 | 4.0 | 4.0 | | 4.0 | | 4.0 |
| | Force reading (Kgf) | New belt 3.0 - 3.2 | 2.8 - 3.0 | 2.8 - 3.1 | 3.7 - 4.0 | 3.7 - 4.0 | 3.4 - 3.6 | 3.4 - 3.6 | 2.9 - 3.1 | 2.9 - 3.0 | 3.3 - 3.5 | 2.9 - 3.1* | 2.9 - 3.1 | 5.6 - 6.0 | 1.7 - 1.8 |
| | Belt Mfr / Type | N/A | N/A | Gates Super HC-MN SPA | N/A | Gates Super HC-MN SPA | N/A | Gates Super HC-MN SPA | N/A | N/A | Gates Super HC-MN SPA | N/A | Gates Super HC-MN SPA | N/A | Gates Super HC-MN SPA |
| Pump Belt | Belt Length | | | 925.0 | | 900.0 | | 925.0 | | | | | 1060.0 | | 950.0 |
| | Belt deflection | h 4.0 | 4.0 | 4.0 | 4.0 | 4.0 | 4.0 | 4.0 | 8.0 | 4.0 | 4.0 | | 4.0 | | 4.0 |
| | Force reading (Kgf) | New belt 1.9 - 2.0 | 1.9 - 2.0 | 1.9 - 2.0 | 2.3 - 2.4 | 2.3 - 2.4 | 2.3 - 2.4 | 2.3 - 2.4 | 2.0 - 2.2 | 2.0 - 2.2 | 2.0 - 2.2 | 2.0 - 2.2 | 2.7 - 2.9 | 3.1 - 3.3 | 2.7 - 2.9 |
| Rotor Belts | Belt Length | | | 925.0 | | 900.0 | | 925.0 | | | | | 1060.0 | | 950.0 |
| | Belt deflection | h 4.0 | 4.0 | 4.0 | 4.0 | 4.0 | 4.0 | 4.0 | 8.0 | 4.0 | 4.0 | | 4.0 | | 4.0 |
| | Force reading (Kgf) | New belt 1.7 - 1.8 | 1.7 - 1.8 | 1.7 - 1.8 | 2.0 - 2.1 | 2.0 - 2.1 | 2.0 - 2.2 | 2.0 - 2.2 | 1.8 - 2.0 | 1.8 - 2.0 | 1.8 - 2.0 | 2.3 - 2.5 | 2.3 - 2.5 | 2.7 - 2.9 | 2.7 - 2.9 |