



CONTENTS

Section	Page No.
INTRODUCTION	1
PURPOSE OF MACHINE	2
MACHINE DIMENSIONS & SPECIFICATIONS	2
PARTS LOCATION DIAGRAMS	3 & 4
SAFE WORKING	5
Operator's Personal Protective Equipment Required	5
Basic Woodchipping Safety	5
General Safety Matters - Do's and Dont's	6
Noise Test	7
OPERATING INSTRUCTIONS	8
Safe Transportation	8
Delivery	8
Operator's Personal Protective Equipment Required	8
Manual Controls	8
Emergency Stopping	8
Starting the Engine	9
Stopping the Engine	9
Daily Checks Before Starting	9
Starting to Chip	9
Chipping	9
Blade Wear	10
Blockages	10
SERVICE INSTRUCTIONS	11
Service Schedule	12
Safe Maintenance	13
Safe Lifting of Chipper	13
Spares	13
Copper Ease Safety Information	13
Engine Manufacturer's Handbook	13
Change Blades	14
Check Fittings	15
Tension Drive Belts	15
Greasing Rotor Bearings	15
Anvil Changing	15
WARRANTY STATEMENT	16
EC DECLARATION OF CONFORMITY CERTIFICATE	17
IDENTIFICATION PLATES	18
DECALS	19 & 20
PARTS LISTS	22 - 27



INTRODUCTION

Thank you for choosing this Timberwolf brushwood chipper. Timberwolf chippers are designed to give safe and dependable service if operated according to the instructions.

Before using your new chipper, please take time to read this manual which contains **IMPORTANT HEALTH AND SAFETY INFORMATION and explains the chipper controls. Failure to do so could result in:**

- personal injury
- equipment damage
- damage to property
- a member of the general public becoming injured

This manual covers the operation and maintenance of the Timberwolf TW13/75G. All information in this manual is based on the latest product information available at the time.

All the information you need to operate the machine safely and effectively is contained within pages 3 to 10. Ensure that all operators are **adequately trained** for operating this machine, especially with regard to **safe working practices**.

Timberwolf's policy of constantly improving their products may involve major or minor changes to the chippers or their accessories. Timberwolf reserves the right to make changes at any time without notice and without incurring any obligation.

Due to improvements in design and performance during production there may be, in some cases, minor discrepancies between the actual chipper and the text in this manual.

The manual should be considered a permanent part of the machine and should remain with it if the machine is resold.

Always follow safe operating and maintenance practices



CAUTION or WARNING

Be aware of this symbol and where shown, carefully follow the instructions.

This caution symbol indicates important safety messages in this manual. When you see this symbol, be alert to the possibility of injury to yourself or others, and carefully read the message that follows.



PURPOSE OF MACHINE

The Timberwolf TW 13/75G brushwood chipper is designed to chip solid wood material up to 75 mm in diameter. It is capable of chipping over 0.75 tonnes of brushwood per hour.

DIMENSIONS

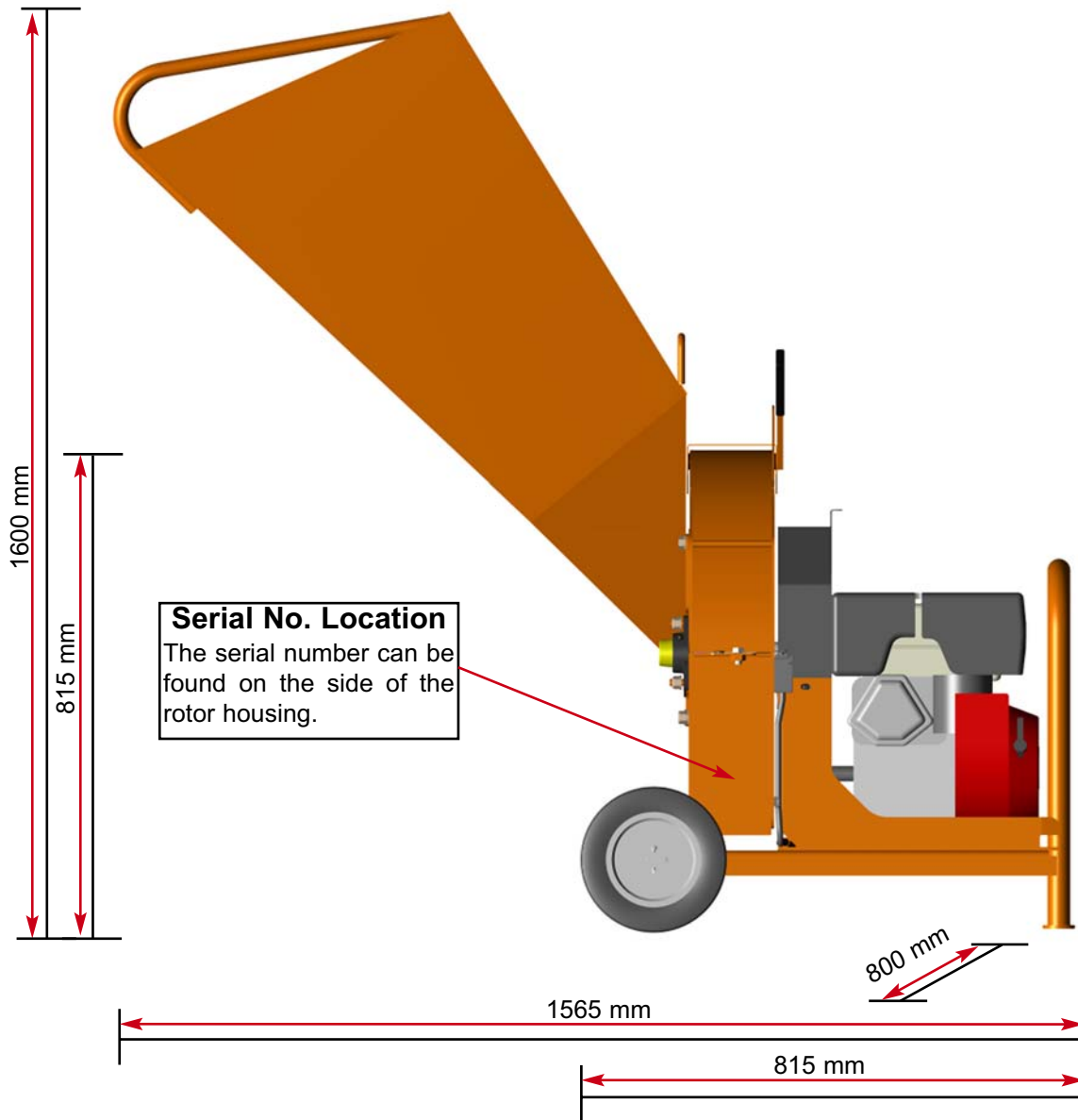

TIMBERWOLF TW 13/75G SPECIFICATION

Engine type	<i>Honda 4 stroke OHV</i>	Type of feed	<i>Gravity</i>
Maximum power	<i>9.6kW (13hp)</i>	Maximum diameter material	<i>75 mm (3")</i>
Cooling method	<i>Air cooled</i>	Fuel capacity	<i>6.5 litres</i>
Overall weight	<i>188kg</i>	Material processing capacity	<i>0.75 tonnes/hr</i>
Starting method	<i>Recoil</i>	Fuel type	<i>Unleaded petrol</i>



PARTS LOCATOR

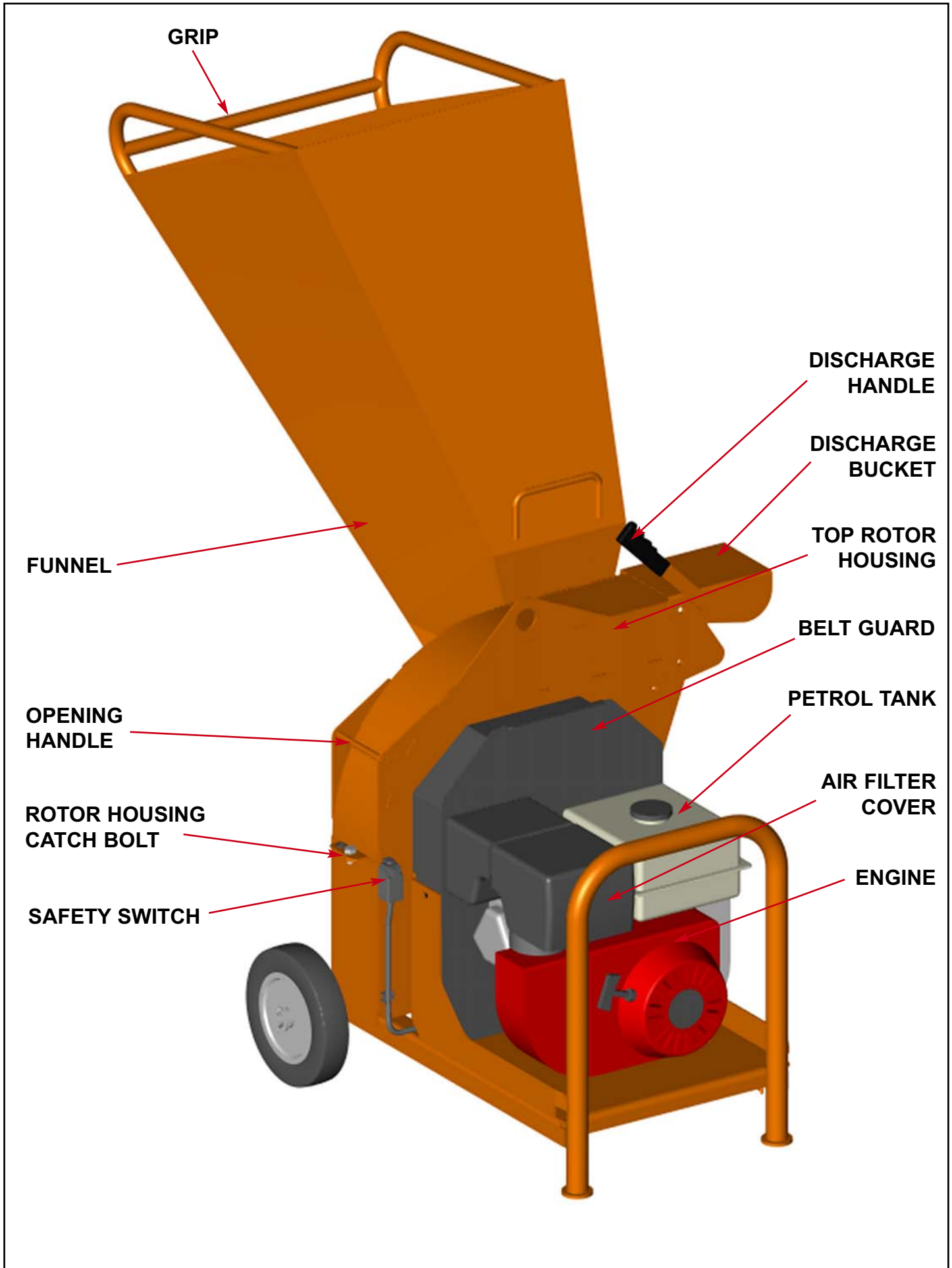

GRIP

DISCHARGE HANDLE

DISCHARGE BUCKET

TOP ROTOR HOUSING

FUNNEL

BELT GUARD

OPENING HANDLE

PETROL TANK

ROTOR HOUSING CATCH BOLT

AIR FILTER COVER

SAFETY SWITCH

ENGINE

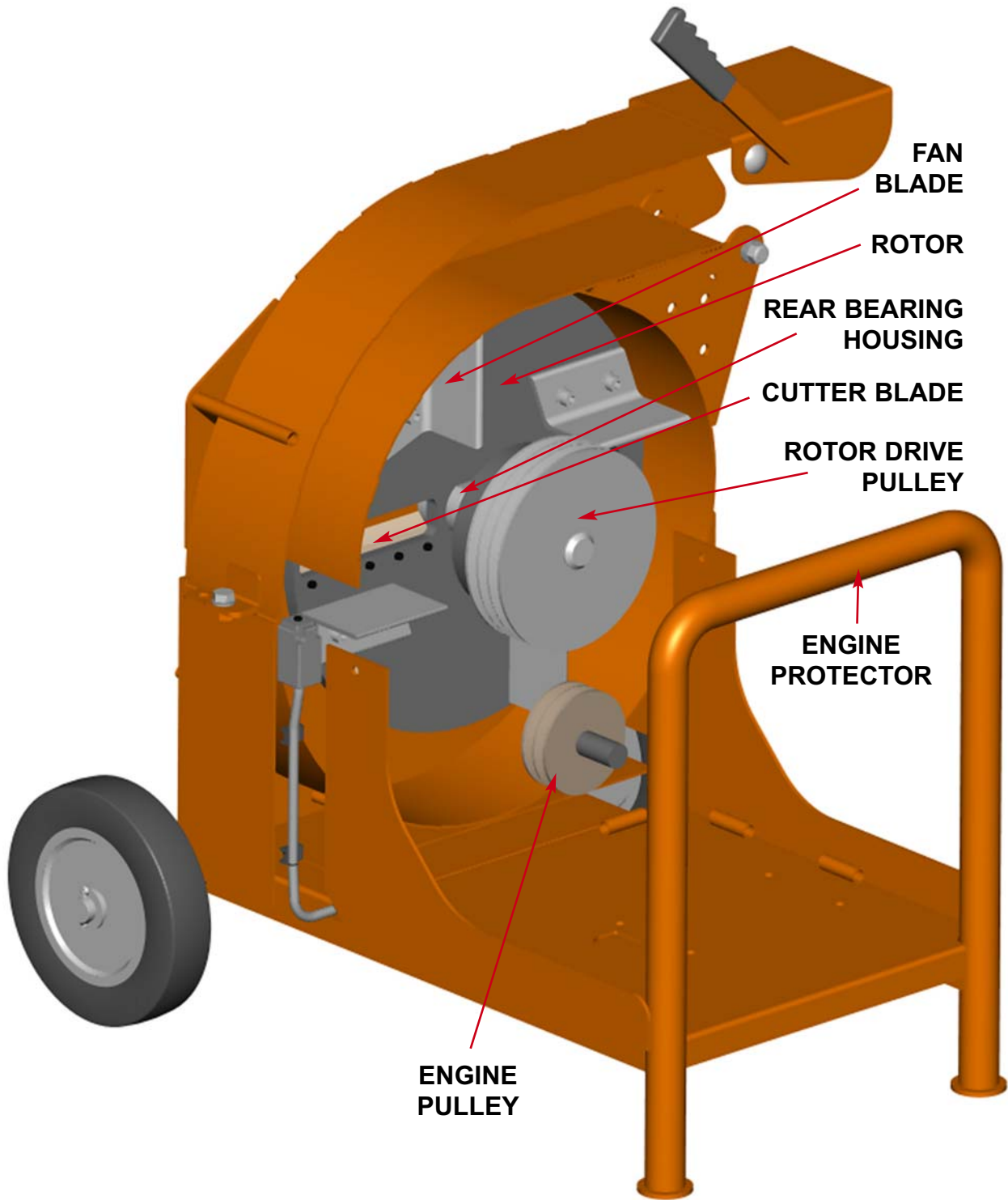



SAFE WORKING

5

WARNING



The chipper will feed material through on its own. To do this, it relies on sharp blades on the chipper rotor. To keep the blades sharp, only feed the machine with clean brushwood. **DO NOT** put muddy/dirty wood, roots, potted plants, bricks, stones or metal into the chipper.



OPERATOR'S PERSONAL PROTECTIVE EQUIPMENT REQUIRED



Chainsaw safety helmet fitted with mesh visor and recommended ear defenders to the appropriate specifications.



Close fitting heavy-duty non-snag clothing.



Work gloves with elasticated wrist.



Face mask if appropriate.



Steel toe cap safety boots.



DO NOT wear rings, bracelets, watches, jewellery or any other items that could be caught in the material and draw you into the chipper.

BASIC WOODCHIPPING SAFETY

The operator should be aware of the following points:

- **MAINTAIN A SAFETY EXCLUSION ZONE** around the chipper of at least 10 metres for the general public or employees without adequate protection. Use hazard tape to identify this working area and keep it clear from debris build up. Chips should be ejected away from any area the general public have access to.
- **HAZARDOUS MATERIAL** - Some species of trees and bushes are poisonous. The chipping action can produce vapour, spray and dust that can irritate the skin. This may lead to respiratory problems or even cause serious poisoning. Check the material to be chipped before you start. Avoid confined spaces and use a facemask if necessary.
- **BE AWARE** when the chipper is processing material that is an awkward shape. The material can move from side to side in the funnel with great force. If the material extends beyond the funnel, the brush may push you to one side causing danger. Badly twisted brush should be trimmed before being chipped to avoid thrashing in the feed funnel.
- **BE AWARE** that the chipper can eject chips out of the feed funnel with considerable force. Always wear full head and face protection.
- **ALWAYS** work on the side of the machine furthest from any local danger, e.g. not road side.



GENERAL SAFETY MATTERS



DO'S AND DON'TS



ALWAYS stop the chipper engine before making any adjustments, refuelling or cleaning.

ALWAYS check rotor has stopped rotating and remove chipper ignition key before maintenance of any kind, or whenever the machine is to be left unattended.

ALWAYS check the machine is well supported and cannot move.

ALWAYS operate the chipper with the engine set to maximum speed when chipping.

ALWAYS check (visually) for fluid leaks.

ALWAYS take regular breaks. Wearing personal protective equipment for long periods can be tiring and hot.

ALWAYS keep hands, feet and clothing out of feed opening, discharge and moving parts.

ALWAYS use the next piece of material or a push stick to push in short pieces. Under no circumstances should you reach into the funnel.



ALWAYS keep the operating area clear of people, animals and children.

ALWAYS keep the operating area clear from debris build up.

ALWAYS keep clear of the chip discharge tube. Foreign objects may be ejected with great force.

ALWAYS ensure protective guarding is in place before commencing work. Failure to do so may result in personal injury or loss of life.

ALWAYS operate the chipper in a well ventilated area - exhaust fumes are dangerous.

DO NOT operate chipper unless available light is sufficient to see clearly.

DO NOT use or attempt to start the chipper without the feed funnel, guards and discharge unit securely in place.

DO NOT stand directly in front of the feed funnel when using the chipper. Stand to one side.

DO NOT allow -

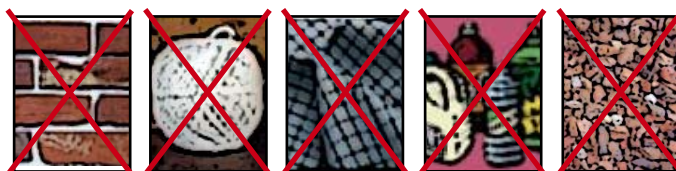

BRICKS STRING CLOTH PLASTIC STONES



METAL GLASS RUBBER ROOTS BEDDING PLANTS

- to enter the machine, as damage is likely.

DO NOT smoke when refuelling.



DO NOT let anyone who has not received instruction operate the machine.

DO NOT climb on the machine at any time.

DO NOT handle material that is partially engaged in the machine.

DO NOT touch any exposed wiring while machine is running.

DO NOT use the chipper inside buildings.



NOISE TEST

MACHINE:	TW 13/75G
NOTES:	TESTED CHIPPING 40 MM X 40 MM CORSICAN PINE 1.5M IN LENGTH

Noise levels above 80dB (A) will be experienced at the working position. Wear ear protection at all times to prevent possible damage to hearing. All persons within a 4 metre radius must also wear good quality ear protection.

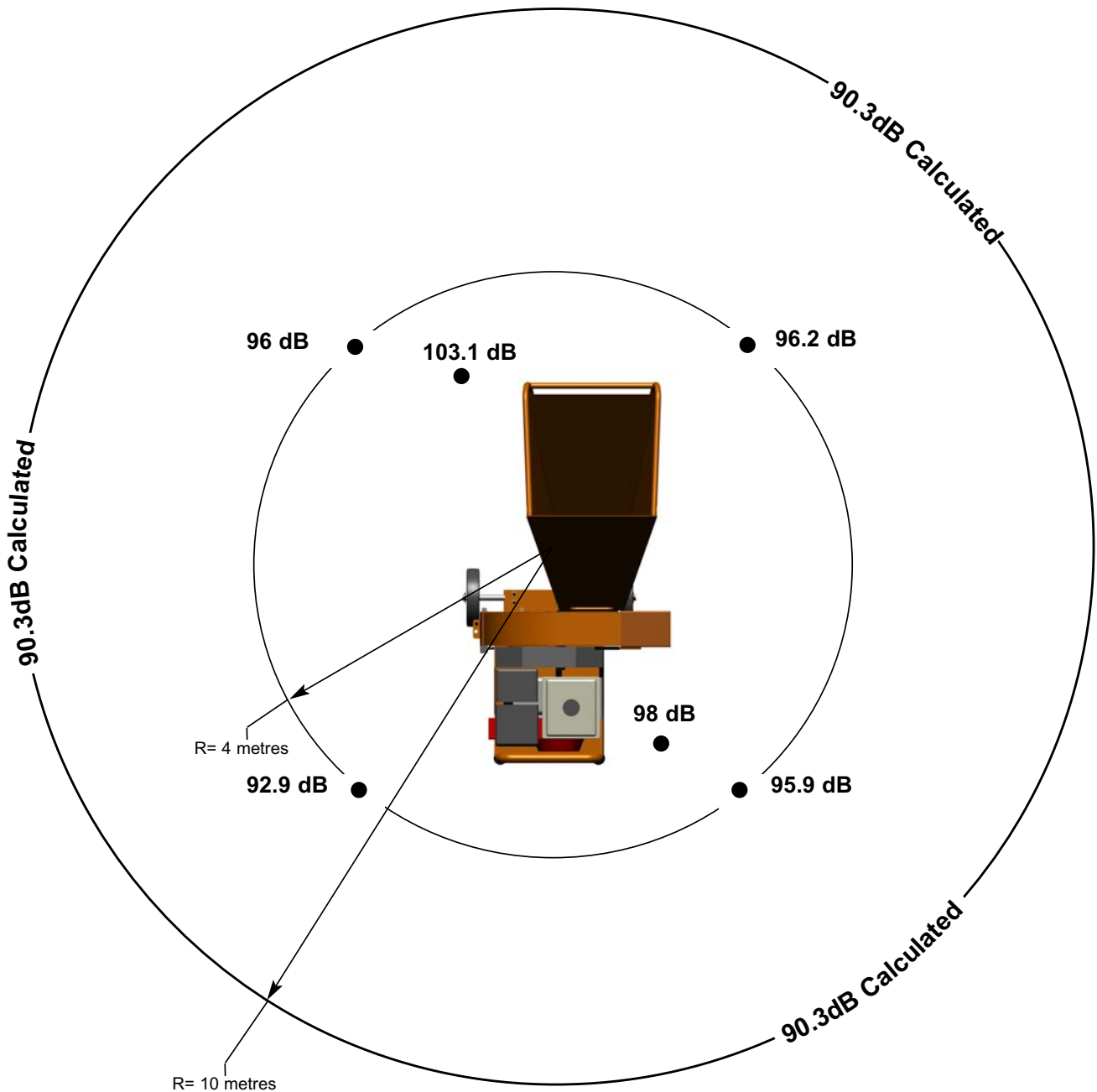

Guaranteed Sound Power: 120dB (A)

As required by Supply of Machinery (safety) regulations of 2008.



SAFE TRANSPORTATION

- **THE** TW 13/75G chipper may be transported as a unit or with the feed funnel removed.
- **TAKE** care when loading the TW 13/75G as it is 183 kg in weight.
- **STRAP** the chipper down firmly before beginning a journey (do not use feed funnel handles to strap down machine).
- **ENSURE** no debris or water is trapped in the rotor housing that may spill during transit.
- **TURN** the fuel valve OFF and keep the engine upright.

DELIVERY

All Timberwolf TW 13/75G machines have a full pre - delivery inspection before leaving the factory and are ready to use. Read and understand this instruction manual before attempting to operate the chipper. In particular, read pages 5 -7 which contain important health and safety information and advice.

OPERATOR'S PERSONAL PROTECTIVE EQUIPMENT REQUIRED

- **CHAINSAW** safety helmet fitted with visor and recommended ear defenders to an appropriate specification.
- **CLOSE - FITTING** heavy-duty non-snap clothing.
- **SAFETY** footwear.
- **FACE MASK** (if appropriate).
- **HEAVY-DUTY** work gloves with elasticated wrist.

See page 5 for more detailed information.

MANUAL CONTROLS

There are four controls on the Honda GX 390 K1 that are required for daily usage of the TW 13/75G chipper.

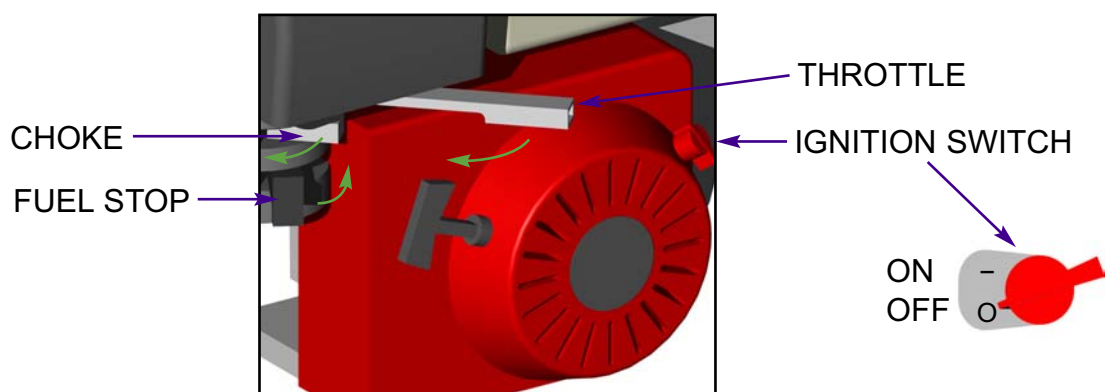

Please refer to the Honda engine manual for instructions of how to start and control the GX390 engine. The chipper does not have any manual controls for normal operation.

EMERGENCY STOPPING

Turn the ignition switch to the 'O' position (as shown above).



STARTING THE ENGINE

- **TURN** the fuel valve to the 'ON' position.
- **MOVE** the choke lever to the 'CLOSE' position. NOTE: Do not use the choke if the engine is warm or the air temperature is high.
- **MOVE** the throttle control lever slightly to the left.
- **TURN** the engine switch to the 'ON' position.
- **PULL** the starter grip lightly until resistance is felt, then pull briskly.
- **CAUTION:** Do not allow the starter grip to snap back against the engine. Return it gently to prevent damage to the starter.
- **AS** the engine warms up, gradually move the choke lever to the 'OPEN' position.
- **POSITION** the throttle control lever for the desired engine speed.

STOPPING THE ENGINE

- **MOVE** the throttle control lever to idle and allow to run for one minute.
- **TURN** the fuel valve to the 'OFF' position.

DAILY CHECKS BEFORE STARTING

- **LOCATE** the machine on firm level ground.
- **CHECK** engine oil level.
- **CHECK** the fuel valve is open.
- **CHECK** all guards are in place.
- **CHECK** the discharge unit is pointing in a safe direction.
- **CHECK** the feed funnel to ensure no objects are inside.

For parts location see diagrams on pages 3 & 4.

STARTING TO CHIP

WARNING



Do not use or attempt to start the chipper without the protective guarding and discharge unit securely in place. Failure to do so may result in personal injury or loss of life.



- **CHECK** that the chipper is running smoothly.
- **STAND** to one side of the feed funnel.
- **PROCEED** to feed material into the feed funnel.

CHIPPING

Wood up to 75 mm in diameter can be fed into the feed funnel. Enter it into the funnel butt end first. Release the material before it engages the rotor. Some pieces of wood may move around significantly whilst being chipped.

The wood will be drawn into the cutting blade quite quickly, be ready for this to happen. Stand well clear.

A piece of wood which is too tough or too large for the chipper will slow the engine down. When this happens it is possible to hold back the branches that are being chipped and allow the engine to regain its speed again.

If a piece of wood gets stuck in the funnel and it cannot be chipped due to its size or shape, it will need to be removed. Trim the branch until it is a suitable shape for the chipper to accept.



BLADE WEAR

The most important part of using a wood chipper is keeping the cutter blades sharp. The TW 13/75G is fitted with one blade 177 mm (7") long. It is 42 mm wide when new.

A new blade should chip between 5 and 10 tonnes of material before sharpening. This figure will be drastically reduced by feeding the machine with stony, sandy or muddy material.

As the blade becomes blunt the machine reduces the feed speed. The discharge will stop being so cleanly cut and have more stringy shreds in it. At this point the blade should be sent to a reputable blade sharpening company. The blade can be sharpened several times in its life. A wear mark on the reverse side indicates the safe limit of blade wear. Replace when this line is exceeded.

BLOCKAGES

Always be aware that what you are putting into the chipper must come out. If the chips stop coming out of the discharge but the chipper is taking material in - STOP IMMEDIATELY. Continuing to feed material into a blocked machine may cause damage and will make it difficult to clear.

If the chipper becomes blocked proceed as follows:

- **STOP** the engine, as per instructions on page 9.
- **REMOVE** the M12 screw that retains the top rotor housing.
- **OPEN** the top rotor housing.
- **WEARING** gloves, reach into the rotor housing and scoop out the debris causing the blockage.

WARNING



Do not reach into the rotor housing with unprotected hands. There are sharp blades and any small movement of the rotor may cause serious injury.





- **IT** is not necessary to remove all the debris, just the majority.
- **CLOSE** the rotor housing and clamp down tightly.
- **RESTART** the engine and increase to full speed.
- **ALLOW** chipper time to clear the rotor housing.
- **FEED** a small piece of wood in to ensure complete clearance.

NOTE

Continuing to feed the chipper with brushwood once it has become blocked will cause the chipper to compact the chips in the rotor housing and it will be difficult and time consuming to clear.

AVOID THIS SITUATION - WATCH THE DISCHARGE TUBE AT ALL TIMES.



 **THE FOLLOWING PAGES DETAIL ONLY
BASIC MAINTENANCE GUIDELINES SPECIFIC
TO YOUR CHIPPER.** 

THIS IS NOT A WORKSHOP MANUAL.

THE FOLLOWING GUIDELINES ARE NOT EXHAUSTIVE AND DO NOT EXTEND TO GENERALLY ACCEPTED STANDARDS OF ENGINEERING/MECHANICAL MAINTENANCE THAT SHOULD BE APPLIED TO ANY PIECE OF MECHANICAL EQUIPMENT AND THE CHASSIS TO WHICH IT IS MOUNTED.

AUTHORISED TIMBERWOLF SERVICE AGENTS ARE FULLY TRAINED IN ALL ASPECTS OF TOTAL SERVICE AND MAINTENANCE OF TIMBERWOLF WOODCHIPPERS. YOU ARE STRONGLY ADVISED TO TAKE YOUR CHIPPER TO AN AUTHORISED AGENT FOR ALL BUT THE MOST ROUTINE MAINTENANCE AND CHECKS.

TIMBERWOLF ACCEPTS NO RESPONSIBILITY FOR THE FAILURE OF THE OWNER/USER OF TIMBERWOLF CHIPPERS TO RECOGNISE GENERALLY ACCEPTED STANDARDS OF ENGINEERING/MECHANICAL MAINTENANCE AND APPLY THEM THROUGHOUT THE MACHINE.

**THE FAILURE TO APPLY GENERALLY ACCEPTED
STANDARDS OF MAINTENANCE, OR THE PERFORMANCE
OF INAPPROPRIATE MAINTENANCE, MAY INVALIDATE
WARRANTY IN WHOLE OR IN PART.**

 **PLEASE REFER TO YOUR AUTHORISED
TIMBERWOLF SERVICE AGENT FOR
SERVICE AND MAINTENANCE.** 



SERVICE INSTRUCTIONS

12

SERVICE SCHEDULE

WARNING



Always immobilise the machine by stopping the engine, removing the ignition key and disconnecting the battery before undertaking any maintenance work.



SERVICE SCHEDULE	Daily Check	25 Hours	50 Hours	500 Hours
Check engine oil - top up if necessary (10W-30).	✓			
Check for engine oil leaks.	✓			
Check fuel level.	✓			
Check feed funnel and belt guard are securely fitted.	✓			
Clean engine air intake.	✓			
Check air filter element.	✓			
Check blade condition.	✓			
Check for tightness all nuts, bolts and fastenings making sure nothing has worked loose.		✓		
Check tension of main drive belts (and tension if necessary).		✓		
Check cutting anvil.			✓	
Grease front rotor bearing.			✓	
Check for loose electrical wiring.				✓
Renew oil filter.] REFER TO YOUR ENGINE SUPPLIERS MANUAL			
Replace spark plugs.				
Check valve clearances.				
Clean air filter.				
Clean sediment cup.				
Clean fuel tank and strainer.				
Check fuel line.				

NOTE: Your Timberwolf woodchipper is covered by a full 12 months parts and labour warranty. Subject to correct maintenance and proper machine usage, the bearings are guaranteed for 12 months regardless of hours worked by the machine. In conditions of 'heavy usage' - i.e. in excess of 500 hours per year - it is recommended that the bearings are changed annually to ensure that the machine retains optimum working performance.



SAFE MAINTENANCE

- **HANDLE** blades with extreme caution to avoid injury. Gloves should always be worn when handling the cutter blades.
- **THE** drive belts should be connected while changing blades, as this will restrict sudden movement of the rotor.
- **THE** major components of this machine are heavy. Lifting equipment must be used for disassembly.
- **CLEAN** machines are safer and easier to service.

SAFE LIFTING OF THE CHIPPER

The lifting eye is designed to lift the machine's weight only. Do not use hoist hook directly on the lifting eye, use a correctly rated safety shackle. Inspect the lifting eye prior to each use - DO NOT USE IF DAMAGED.

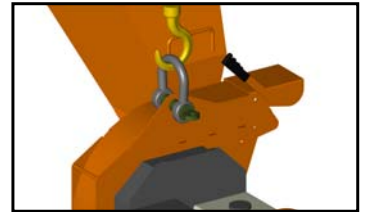

SPARES

Only fit genuine Timberwolf replacement blades, screws and chipper spares. Failure to do so will result in the invalidation of the warranty and may result in damage to the chipper, personal injury or even loss of life.

COPPER EASE SAFETY INFORMATION

Product name: Copper Ease.

Copper Ease contains no hazardous ingredients at or above regulatory disclosure limits, however, safety precautions should be taken when handling (use of oil-resistant gloves and safety glasses are recommended - respiratory protection is not required). Avoid direct contact with the substance and store in a cool, well ventilated area avoiding sources of ignition, strong oxidising agents and strong acids. Dispose of as normal industrial waste (be aware of the possible existence of regional or national regulations regarding disposal), do not discharge into drains or rivers.

In case of fire: in combustion the product emits toxic fumes, extinguish with alcohol or polymer foam, carbon dioxide or dry chemical powder. Wear self-contained breathing apparatus and protective clothing to prevent contact with skin and eyes.

FIRST AID

Skin contact: there may be mild irritation at the site of contact, wash immediately with plenty of soap and water.

Eye contact: there may be irritation and redness, bathe the eye with running water for 15 minutes.

Ingestion: there may be irritation of the throat, do not induce vomiting, wash out mouth with water.

A safety data sheet for this product can be obtained by writing to the manufacturer at the following address: Comma Oil and Chemicals Ltd., Deering Way, Gravesend, Kent DA12 2QX. Tel: 01474 564311, Fax: 01474 333000.

ENGINE MANUFACTURER'S HANDBOOK

Refer to your Engine Manufacturer's Handbook for detailed instructions on the following:

- Changing the fuel filter.
- Changing the engine oil.
- Checking the engine oil.
- Changing the engine oil filter.



CHANGE BLADES

WARNING

Wear riggers gloves for the blade changing operation.

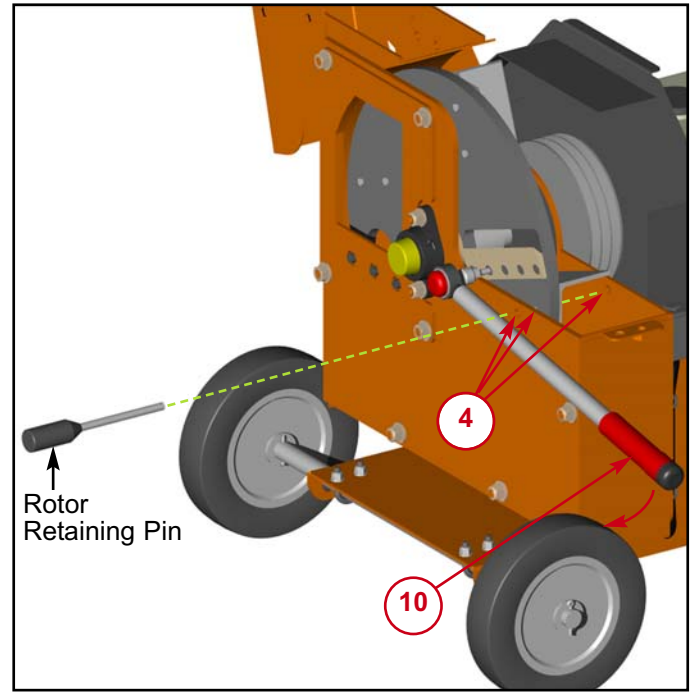
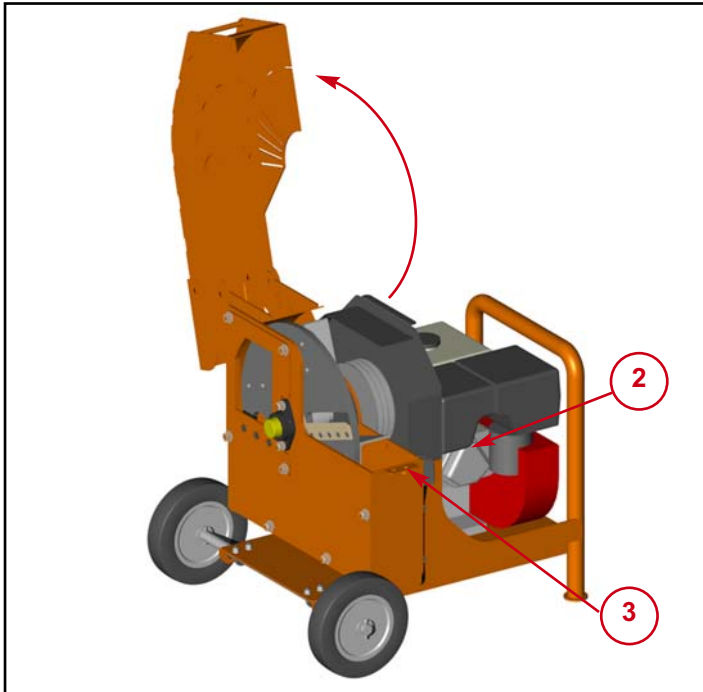

1. Turn engine off, as per instructions on page 9.
2. Pull the plug cap from the spark plug.
3. Remove the M12 screw that retains the top rotor housing using a 19 mm spanner.
4. Turn the rotor by hand using the fan blades so that holes (4) are aligned and insert the 2496F Rotor Retaining Pin (supplied in tool kit).
5. Use a small screw driver to clean out the star socket screws heads retaining the blade.
6. Undo blade screws using the star socket provided.
7. **Before fitting replacement blades ensure the blade seat is clean. No material should be allowed to sit between the blade and the rotor.**
8. Check screws being replaced are not damaged. If so, these should be renewed.
9. Apply a thin layer of copper grease to the entire screw thread.
10. **Retighten the screws to 29Nm (22lb/ft)**
This torque setting is vitally important to ensure your bolts come out at a later date. Timberwolf recommend you purchase a torque wrench for this and other jobs on the chipper.
11. Remove Rotor Retaining Pin.
12. Close rotor housing and replace retaining screw.
13. Refit spark plug cap to spark plug.

WARNING

Always sharpen blades on a regular basis. Failure to do so will cause the machine to under perform and will overload engine and bearings causing machine breakdown. Blades must not be sharpened beyond the wear mark (see diagram). Failure to comply with this could result in machine damage, injury or loss of life.

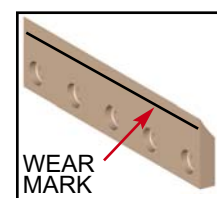



CHECK FITTINGS

The Timberwolf TW 13/75G is subject to large vibrations during the normal course of operation. Consequently there is always a possibility that nuts and bolts will work themselves loose. It is important that periodic checks are made to ensure the security of all fasteners. Fasteners should be tightened using a torque wrench to the required torque (see below). **Uncalibrated torque wrenches can be inaccurate by as much as 25%. It is therefore essential that a calibrated torque wrench is used to achieve the tightening torques listed below.**

	Size	Pitch	Head	Torque lbft	Torque Nm
Rotor Housing Clamp	M12	Standard	19 mm Hex	60	80
Blade Bolts	M8	Standard	T40 Torq	22	29
Funnel Retaining Nuts	M12	Standard	19 mm Hex	60	80
General	M8	Standard	13 mm Hex	17	23
General	M10	Standard	17 mm Hex	34	46
General	M12	Standard	19 mm Hex	60	80

TENSION DRIVE BELTS

NOTE: There will normally be a rapid drop in tension during run-in period for new belts. When new belts are fitted, check the tension every 2 - 3 hours and adjust until the tension remains constant.

Belt failures due to lack of correct tensioning will not be covered under your Timberwolf warranty.

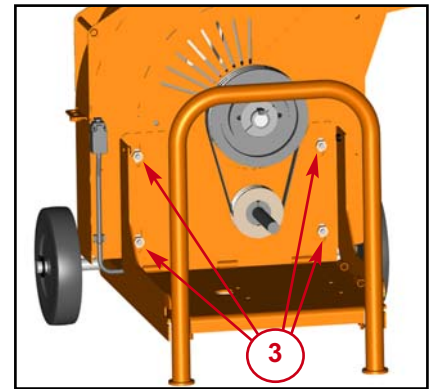
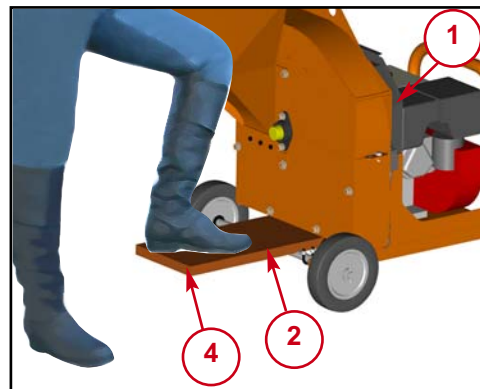

1. Remove the belt guard.
2. Insert a piece of wood approximately 25mm x 150mm x 1200mm (1"x 6"x 48") in the gap as shown.
3. Loosen the four Nyloc nuts located behind the engine.
4. With the chipper firmly supported use the piece of wood to lever the rotor housing upwards.
5. For instructions on checking belt tension & correct belt tension values, please refer to the Timberwolf V-Belt Tensioning Data Table (pg 27).
6. As the belts become taught retighten the four Nyloc nuts.
7. Replace the belt guard.
8. Remove the piece of wood.

GREASING ROTOR BEARINGS

1. Remove rubber cap from front bearing housing grease nipple.
2. Apply 1 pump of grease to bearing.
3. Replace cap.

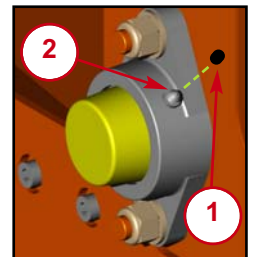

ANVIL CHANGING

The anvil is an important component in maintaining a consistent machine performance. Inspect it through an open rotor housing. A measure of the wear is how sharp the edge is. If it has become seriously rounded then it is appropriate to change it.

Turning or replacing the anvil should be carried out by a Timberwolf dealer.



ENVIRONMENTAL MANUFACTURING LLP 12 MONTH CHIPPER WARRANTY

WARRANTY PERIOD

The warranty period for the woodchipper commences on the date of sale to the first end user and continues for a period of 12 months. This guarantee is to the first end user only and is not transferable except when an authorised Timberwolf Dealer has a woodchipper registered with Environmental Manufacturing LLP as a hire chipper or long term demonstrator – in these situations they are duly authorised to transfer any remaining warranty period to their first end user. Any warranty offered by the Timberwolf Dealer beyond the original 12 month period will be wholly covered by said Dealer.

LIABILITY

Our obligation under this warranty is limited to repair at Environmental Manufacturing LLP premises or at our option an Environmental Manufacturing LLP approved Timberwolf dealer. No liability will be accepted for special, indirect, incidental, or consequential loss or damages of any kind.

WARRANTY STATEMENT

Environmental Manufacturing LLP warrants to the first end user that;

- Your woodchipper shall be designed, built and equipped, at the point of sale, to meet all current applicable regulations.
- Your chipper shall be free from manufacturing defects both in materials and workmanship in normal service for the period mentioned above.

Warranty will not apply to a failure where normal use has exhausted the life of a component.

Engine units are covered independently by their respective manufacturer warranties.

OWNERS WARRANTY RESPONSIBILITIES

As the owner of an Environmental Manufacturing LLP woodchipper you are responsible for the following;

- Operation of the woodchipper in accordance with the Environmental Manufacturing LLP instruction manual.
- Performance of the required maintenance listed in your Environmental Manufacturing LLP instruction manual.
- In the event of a failure the Environmental Manufacturing LLP authorised Timberwolf dealer is to be notified within 10 days of failure and the equipment is to be made available for unmolested inspection by the dealer technician.

WARRANTY RESTRICTIONS

The Environmental Manufacturing LLP warranty is restricted to the first end user only and is not transferable except when an authorised Timberwolf Dealer has a woodchipper registered with Environmental Manufacturing LLP as a hire chipper or long term demonstrator – in these situations they are duly authorised to transfer any remaining warranty period to their first end user.

The Environmental Manufacturing LLP warranty may be invalidated if any of the following apply;

- The failed parts or assembly is interfered with in any way.
- Normal maintenance has not been performed.
- Incorrect reassembly of components.
- The machine has undergone modifications not approved in writing by Environmental Manufacturing LLP.
- In the case of tractor driven equipment, use has been on an unapproved tractor.
- Conditions of use can be deemed abnormal.
- The machine has been used to perform tasks contrary to those stated in the Environmental Manufacturing LLP instruction manual.

WARRANTY SERVICE

To obtain warranty service please contact your nearest Environmental Manufacturing LLP approved Timberwolf dealer. To obtain details of the nearest facility please contact Environmental Manufacturing LLP at the address on the front of this manual.

These warranty terms are in addition to and not in substitution for and do not affect any right and remedies which an owner might have under statute or at common law against the seller of the goods under the contract by which the owner acquired the goods.



CERTIFICATE OF CONFORMITY 17

Environmental Manufacturing LLP

Entec House,
Tomo Industrial Estate,
Stowmarket,
Suffolk IP14 5AY
Tel: 01449 765800 Fax: 01449 765801

E C Declaration of Conformity



Environmental Manufacturing LLP as the designer and manufacturer, certifies that the machine stipulated below complies with all the relevant provisions of the:

Machinery Directive (98/37/EC) (& other relevant directives)

and the National Laws and Regulations adopting these directives.

Designer/Manufacturer : Environmental Manufacturing LLP
Description of Machinery : Self-powered portable machine intended to chip up tree waste prior to disposal.
Model : TW 13/75G
Serial No. : Serial Manufacture

Harmonised standards applied: (including parts/clauses of):

BS EN 292:1991, BS EN 294: 1992, BS EN 60204: 1: 1998, BS EN 563: 1994 -Safety of Machinery – Temperatures of touchable surfaces, BS EN 954-1: 1996 – Safety of Machinery – Safety related parts of control systems, BS EN 982: 1996 – Safety of Machinery – Hydraulics, BS EN 1088: 1995 – Safety of Machinery – Interlocking devices, prEN 13525: 1999 – Forestry Machinery – Wood chippers – Safety.

“Responsible” Person empowered to sign:  Mr. Jeff Haines
Position in Company: Technical Director

Date: 6/4/2007



		ENVIRONMENTAL MANUFACTURING LLP STOWMARKET, SUFFOLK IP14 5AY UK		
MODEL	<input type="text"/>			
SERIAL NO.	<input type="text"/>			
CARR. TYP/SN.	<input type="text"/>	GROSS WEIGHT	<input type="text"/>	
NOM. POWER	<input type="text"/>	DATE	<input type="text"/>	

EXAMPLE



DECALS



616



617



670

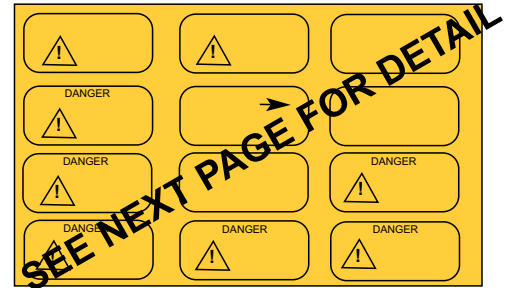

671

TIMBERWOLF

x 2

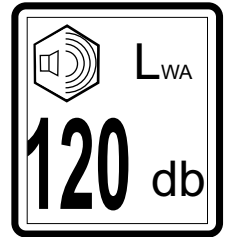

1136

1363

1522

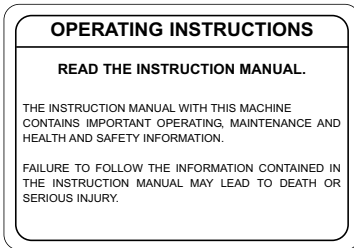

1662

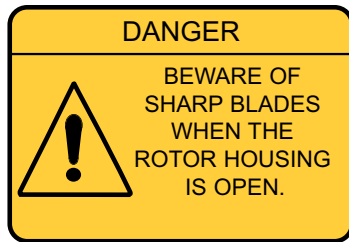

2944



2948

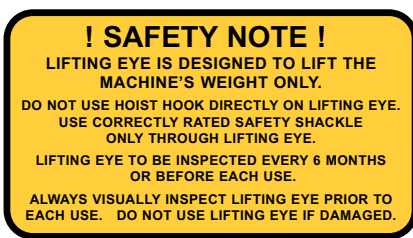

2949

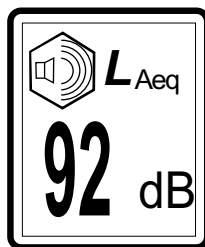

3004

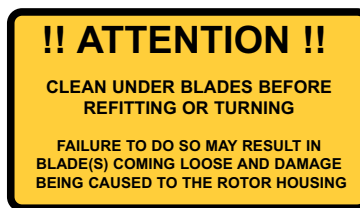

3022



X2

4099



17290



17294

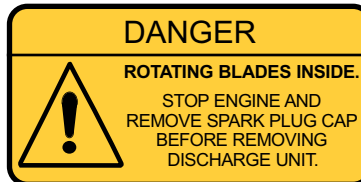









18322



18393



671 - these individual decals are supplied as a set, they may not all apply to your machine.

<p>DANGER</p> <p>DO NOT OPERATE WITHOUT THIS COVER IN PLACE</p> 	<p>DANGER</p> <p>AUTOFEED SYSTEM FITTED. ROLLERS MAY TURN WITHOUT WARNING! WHEN ENGINE IS SWITCHED OFF THE ROLLERS WILL TURN DURING THE RUN DOWN PERIOD</p> 	<p>CAUTION</p> <p>WHEN TRANSPORTING DISCHARGE CLAMPS MAY WORK LOOSE. CHECK FREQUENTLY</p>
<p>DANGER</p> <p>DO NOT OPERATE WITHOUT THIS COVER IN PLACE</p> 	<p>FUEL HERE </p> <p>RISK OF FIRE</p> <p>ALLOW ENGINE TO COOL FOR 1 MINUTE BEFORE REFUELING. USE UNLEADED PETROL</p>	<p>CAUTION</p> <p>AVOID STANDING DIRECTLY IN FRONT OF FEED FUNNEL TO REDUCE EXPOSURE TO NOISE, DUST AND RISK FROM EJECTED PARTICLES</p>
<p>DANGER</p> <p>DO NOT OPERATE WITHOUT THIS COVER IN PLACE</p> 	<p>CAUTION</p> <p>DO NOT PUT ROAD SWEEPINGS IN MACHINE AS GRIT WILL DAMAGE BLADES</p>	<p>DANGER</p> <p>ROTATING BLADES</p> 
<p>DANGER</p> <p>DO NOT OPERATE WITHOUT THIS COVER IN PLACE</p> 	<p>DANGER</p> <p>STOP ENGINE AND REMOVE KEY BEFORE REMOVING DISCHARGE UNIT. ROTATING BLADES INSIDE.</p> 	<p>DANGER</p> <p>DO NOT USE THIS MACHINE WITHOUT THE DISCHARGE UNIT FITTED FAILURE TO COMPLY MAY RESULT IN SERIOUS INJURY OR DAMAGE</p> 

(Blank)

TIMBERWOLF 13/75G

PARTS LISTS

The following illustrations are for parts identification only. The removal or fitting of these parts may cause a hazard and should only be carried out by trained personnel.

	<i>Page No.</i>
CHASSIS / ROTOR HOUSING	23
DECALS	19 & 20
ENGINE	24
FUNNEL / DISCHARGE	25
ROTOR	26
V- BELT TENSIONING TABLE	27

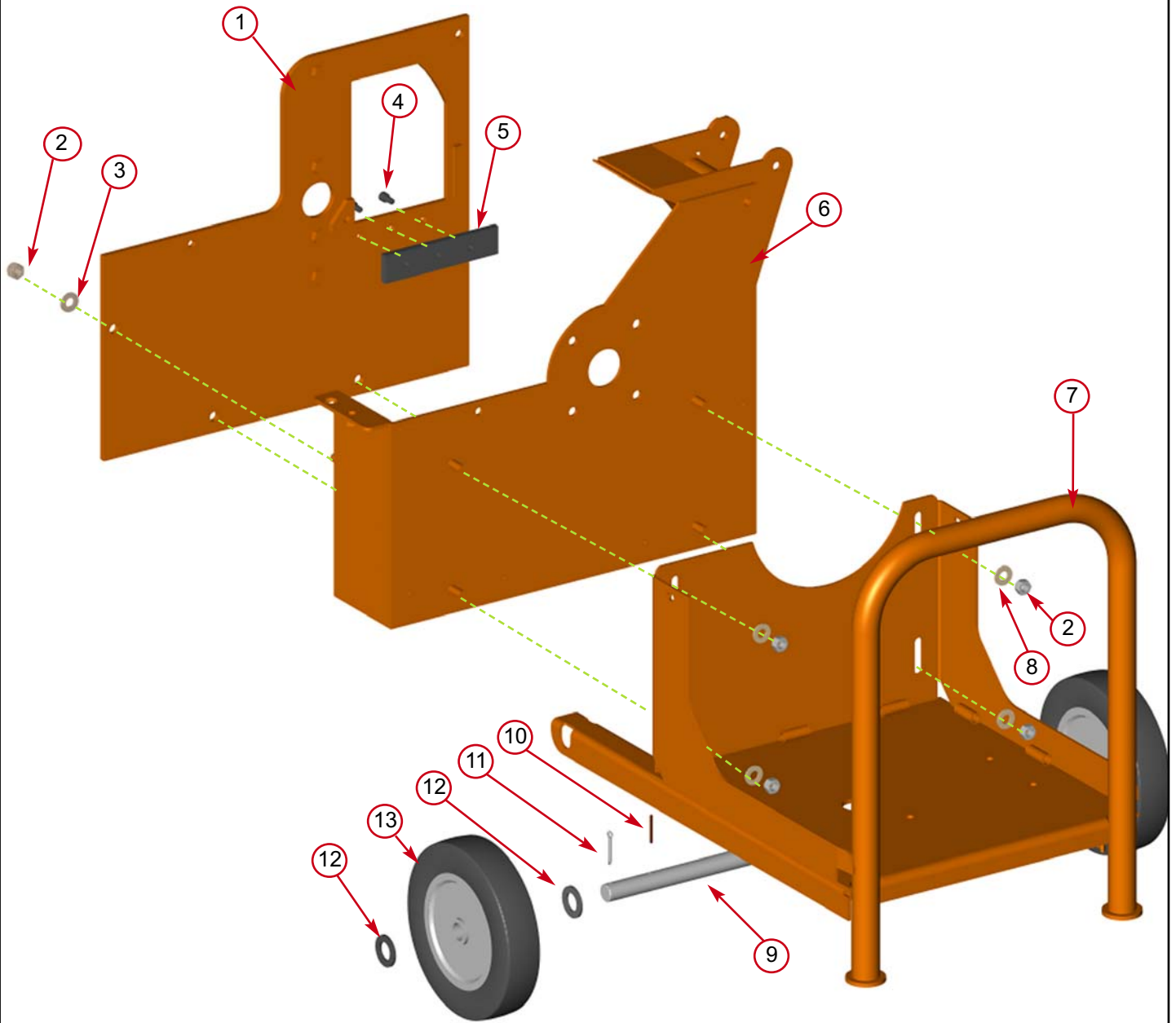

Item	Part No	Part Name	Q'ty
1	1567FO	Front Plate	1
2	0644	M12 P Nyloc Nut	4
3	0702	M12 A Washer	3
4	0345	Capheads	3
5	0105MH	Gravity Anvil	1
6	18452FO	Main Rotor Housing	1
7	2475FO	Chassis	1
8	0704	M12 C Washer	4
9	2476MS	Axle	1
10	0068M	Roll Pin	4
11	0528	Split Pin	2
12	0707	M24 A Washer	4
13	2478	Wheel	2



ENGINE

24

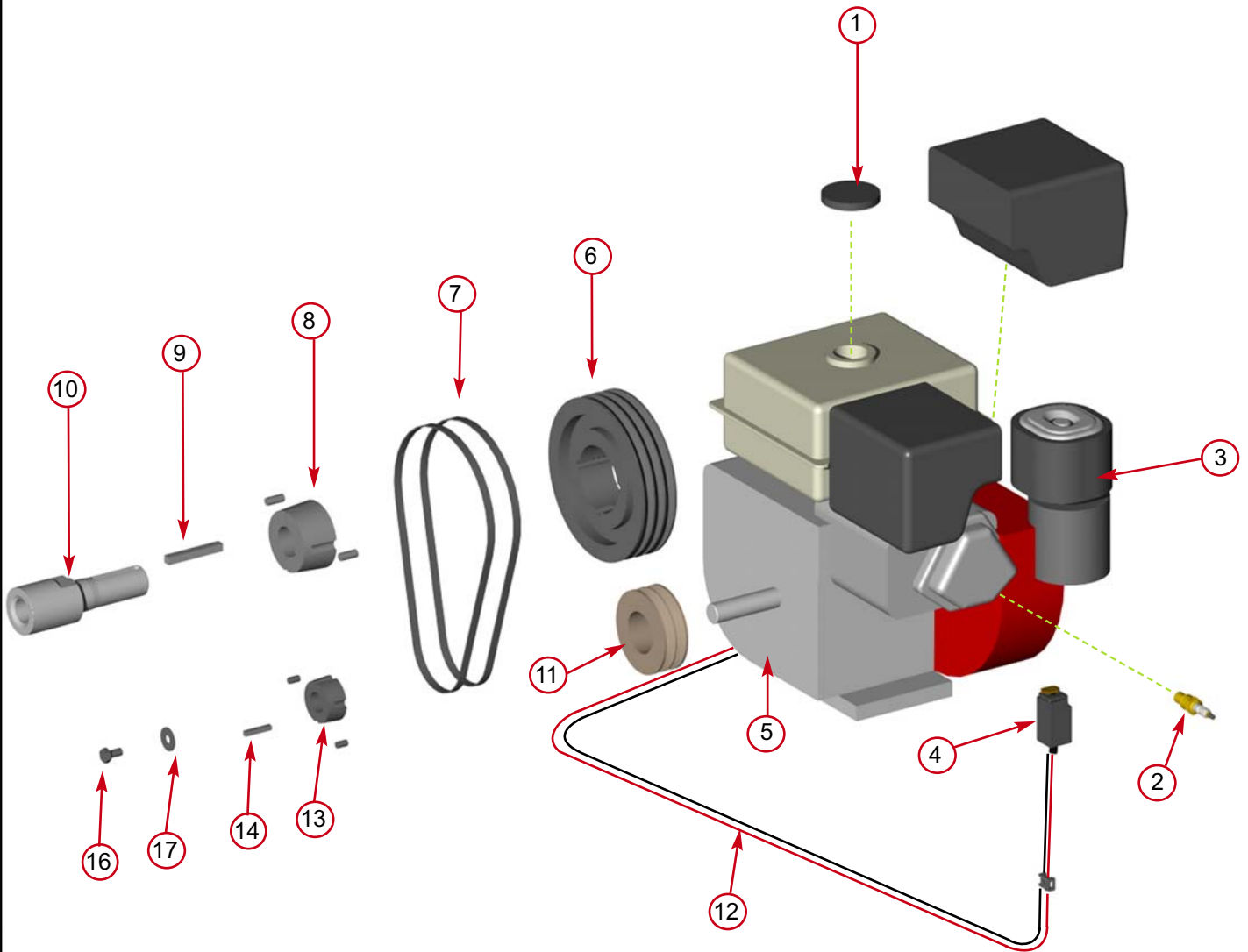

Date Last Modified: 10th Sept 09

Item	Part No	Part Name	Q'ty	Item	Part No	Part Name	Q'ty
1	supp'd with engine	Fuel Cap	1	9	18960M	Rotor Shaft Key	1
2	supp'd with engine	Spark Plug	1	10	4280M	Rear Shaft	1
3	supp'd with engine	Air Filter	1	11	1135	Pulley 118-2 SPA	1
4	1348	Safety Switch	1	12	2494	Stop Loom	1
5	1172	Honda Engine	1	13	0405	Bush 1610	1
6	1351	Pulley 200-3 SPA	1	14	0061	Engine Shaft Key	1
7	1533	Belt 900 XPA 2	2	16	17283	Long Socket Head Screw	1
8	0410	Bush 2517	1	17	4344	M10/30 Washer	1



FUNNEL/DISCHARGE

25

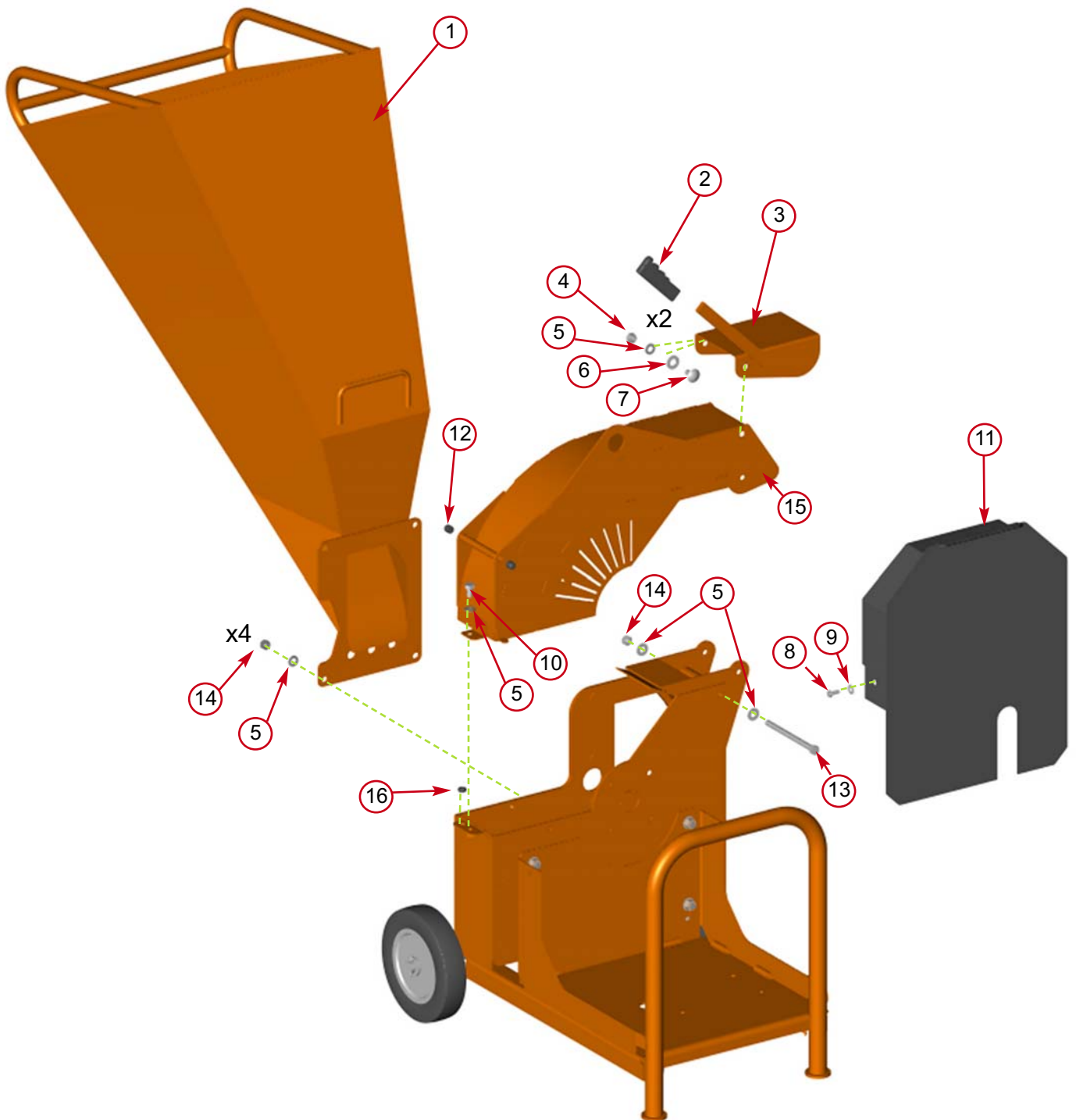

Date Last Modified: 24th Jan 08

Item	Part No	Part Name	Q'ty	Item	Part No	Part Name	Q'ty
1	1642FO	Funnel	1	9	0712	M8 C Washer	2
2	0134	Plastic Grip	1	10	0318	M12/20 Bolt	1
3	1052FO	Discharge Bucket	1	11	2000FB	Belt Guard	1
4	0045	M12 T Nyloc Nut	2	12	2493	13 mm Plastic Plug	2
5	0702	M12 A Washer	11	13	17336	M12/170 Bolt	1
6	1143	M16 A Washer	2	14	0046	M12 Plain Nut	5
7	0320	M12/25 Cup Square	2	15	18453FO	Discharge	1
8	0346	M8/20 Bolt	2	16	0654	Rubber Grommet	1



ROTOR

26

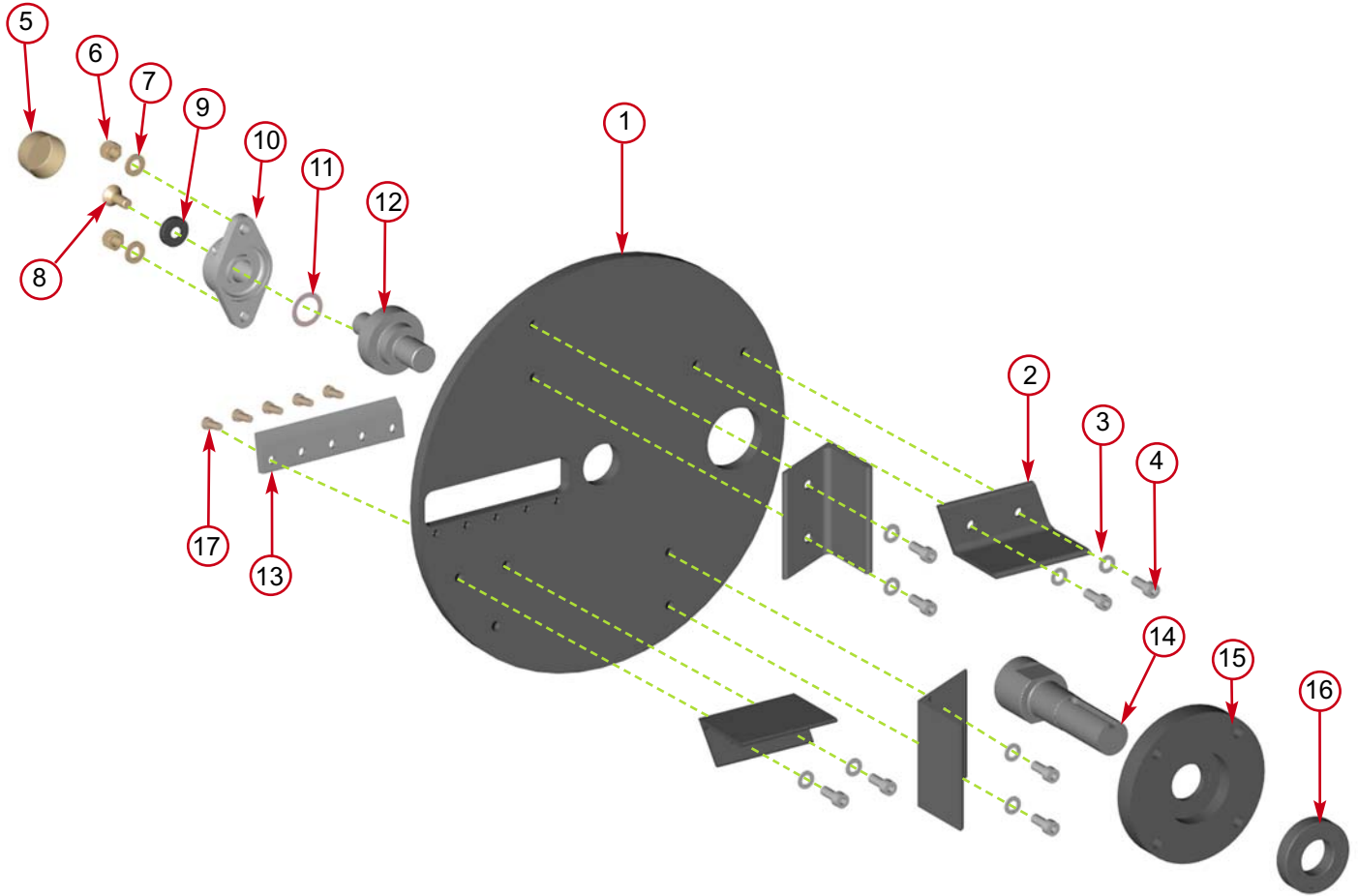

Date Last Modified: 10th Sept 09

Item	Part No	Part Name	Q'ty	Item	Part No	Part Name	Q'ty
1	17342M	Rotor	1	10	0648	Bearing Front SFT25	1
2	17317F	Fan Blade	4	11	0796	20 thou Shim	As Req'd
3	0701	M10 A Washer	8	12	1061M	Nose Shaft	1
4	0305	M10/25 Caphead	8	13	071MH	Blade	1
5	0633	Bearing Cap	1	14	18948M	Rear Shaft	1
6	0644	M12 P Nyloc Nut	2	15	4063MCB	Bearing Housing Rear	1
7	0702	M12 A Washer	2	16	0495	Bearing	1
8	0428	M12/30 C'sunk Patched	1	17	0065	M8/20 Blade Bolt	5
9	0713	Heavy C'sunk Washer	1				



V-BELT TENSIONING TABLE

TIMBERWOLF V-BELT TENSIONING DATA TABLE

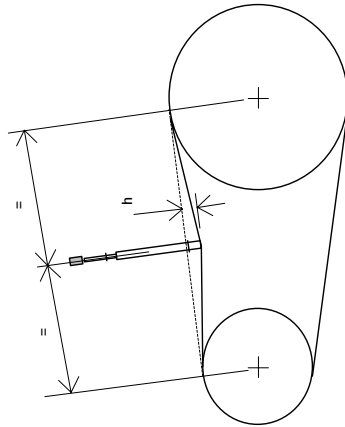

METHOD:

1. SET THE DEFLECTION DISTANCE ON THE LOWER SCALE OF THE TENSION GAUGE SO THAT THE UNDERSIDE OF THE 'O'-RING EQUALS THE 'in' VALUE GIVEN IN THE TABLE BELOW
2. ENSURE THAT THE DEFLECTION FORCE SCALE IS ZERO'D BY PUSHING THE UPPER 'O'-RING ALL THE WAY DOWN
3. PLACE THE TENSION GAUGE IN THE CENTRE OF THE BELT SPAN AS SHOWN IN THE DIAGRAM LEFT
4. PRESS DOWNWARDS ON THE RUBBER BUFFER, DEFLECTING THE BELT UNTIL THE UNDERSIDE OF THE LOWER O-RING IS LEVEL WITH THE BELT BEHIND (USE A STRAIGHT EDGE IF THERE IS ONLY 1 BELT)
5. TAKE THE READING FROM THE DEFLECTION SCALE OF THE TENSION METER (READ AT THE LOWER EDGE OF THE 'O'-RING) & COMPARE THIS VALUE WITH THAT GIVEN IN THE TABLE BELOW
6. TIGHTEN OR LOOSEN BELTS AS REQUIRED FOLLOWING PROCEDURE GIVEN IN THE OPERATOR'S MANUAL

TENSION GAUGES ARE AVAILABLE FROM TIMBERWOLF SPARES, QUOTING PART No. 18091

TIPS ON BELT TIGHTENING:

- A) THERE WILL NORMALLY BE A RAPID DROP IN TENSION DURING THE RUN-IN PERIOD FOR NEW BELTS. WHEN NEW BELTS ARE FITTED, CHECK THE TENSION EVERY 2-3 HOURS & ADJUST UNTIL THE TENSION REMAINS CONSTANT
- B) THE BEST TENSION FOR V-BELT DRIVES IS THE LOWEST TENSION AT WHICH THE BELTS DO NOT SLIP OR RATCHET UNDER THE HIGHEST LOAD CONDITION
- C) TOO MUCH TENSION SHORTENS BELT & BEARING LIFE
- D) TOO LITTLE TENSION WILL AFFECT THE PERFORMANCE OF YOUR MACHINE ESPECIALLY IN RESPECT OF NO-STRESS DEVICES
- E) ENSURE THAT BELT DRIVES ARE KEPT FREE OF ANY FOREIGN MATERIALS
- F) IF A BELT SLIPS - TIGHTEN IT!

TW MODEL No.:	13/75G	18/100G	125PH	150DH/DHB	150FTR	150VTR	190DH	190FTR	190TDH	190TFTR 190TVGTR	230TR	250DH	PTO100	PTO150	PTO300	S425/S426 SHREDDER
	Gates Super HC-MIN	Gates Super HC-MIN	Gates Super HC-MIN	Gates Super HC-MIN	Gates Super HC-MIN	Gates Super HC-MIN	Gates Super HC-MIN	Gates Super HC-MIN	Gates Super HC-MIN	Gates Super HC-MIN	Gates Super HC-MIN	Gates Quad Power II	Gates Super HC-MIN	Gates Super HC-MIN	Gates Super HC-MIN	Gates Super HC-MIN
Belt Mfr / Type	SPA	SPA	SPA	SPA	SPA	SPA	SPA	SPA	SPA	SPA	SPA	XPB	SPA	SPA	SPA	SPB
Belt Pitch Designation	900.0	1060.0	1060.0	1060.0	1060.0	1060.0	1232.0	1232.0	1232.0	1232.0	1950.0	3350.0	900.0	900.0	900.0	2120.0
Belt Length	h	4.0	4.0	4.0	4.0	4.0	4.0	4.0	4.0	4.0	6.0	10.0	4.0	4.0	4.0	8.0
Belt deflection																
Force reading (Kgf)	New belt	3.4 - 3.6	3.1 - 3.3	3.0 - 3.2	4.3 - 4.5	4.3 - 4.5	3.3 - 3.5	3.3 - 3.5	3.9 - 4.1	3.9 - 4.1	3.4 - 3.6	3.5 - 3.7*	3.3 - 3.5	3.8 - 4.0	3.3 - 3.5	3.3 - 3.5*
	Used belt	3.0 - 3.2	2.8 - 3.0	2.7 - 2.9	3.7 - 4.0	3.7 - 4.0	2.8 - 3.0	2.8 - 3.0	3.4 - 3.6	3.4 - 3.6	3.0 - 3.2	3.1 - 3.3*	2.9 - 3.0	3.3 - 3.5	3.3 - 3.5	2.9 - 3.1*
Belt Mfr / Type	N/A	N/A	Gates Super HC-MIN	N/A	Gates Super HC-MIN	Gates Super HC-MIN	N/A	Gates Super HC-MIN	N/A	Gates Super HC-MIN	Gates Super HC-MIN	N/A	N/A	Gates Super HC-MIN	Gates Super HC-MIN	N/A
Belt Pitch Designation			SPA		SPA	SPA		SPA		SPA	SPA			SPA	SPA	
Belt Length			950.0		900.0	900.0		925.0		925.0	950.0			950.0	1000.0	
Belt deflection			4.0		4.0	4.0		4.0		4.0	4.0			4.0	4.0	
Force reading (Kgf) Ver 2.0 - 12-10-07	New belt		1.9 - 2.0		2.3 - 2.4	2.3 - 2.4		2.3 - 2.4		2.3 - 2.4	1.5 - 1.6			2.0 - 2.2	1.9 - 2.0	
	Used belt		1.7 - 1.8		2.0 - 2.1	2.0 - 2.1		2.0 - 2.2		2.0 - 2.2	1.3 - 1.4			1.8 - 2.0	1.7 - 1.8	

* DUE TO THE EXTENDED BELT SPAN LENGTHS ON THE 250DH & S425/S426 SHREDDER, THE FORCE READINGS ARE INCREASED BY 0.5Kgf OVER THE DESIGN IQ OUTPUTS