



<i>Section</i>	<i>Page No.</i>
<b>INTRODUCTION</b>	<b>1</b>
<b>PURPOSE OF MACHINE</b>	<b>2</b>
<b>MACHINE DIMENSIONS &amp; SPECIFICATIONS</b>	<b>2</b>
<b>PARTS LOCATION DIAGRAMS</b>	<b>3 &amp; 4</b>
<b>SAFE WORKING</b>	<b>5</b>
Operator's Personal Protective Equipment Required	5
Basic Woodchipping Safety	5
General Safety Matters - Do's and Dont's	6
Noise Test	7
<b>OPERATING INSTRUCTIONS</b>	<b>8</b>
Safe Transportation	8
Delivery	8
Operator's Personal Protective Equipment Required	8
Hitching Up	8
Connecting PTO Shaft	9
Daily Checks Before Starting	9
Starting to Chip	9
Chipping	9
Blade Wear	10
Blockages	10
<b>SERVICE INSTRUCTIONS</b>	<b>11</b>
Service Schedule	12
Spares	12
Copper Ease Safety Information	12
Safe Maintenance	13
Check Fittings	13
Tension Drive Belts	13
Anvil Changing	13
Change Rotor Bearings	13
Change Blades	14
Change Gear Box Oil	14
Check Wheel Grease Points	14
Safe Lifting of the Chipper	14
<b>WARRANTY STATEMENT</b>	<b>15</b>
<b>EC DECLARATION OF INCORPORATION CERTIFICATE</b>	<b>16</b>
<b>IDENTIFICATION PLATE</b>	<b>17</b>
<b>DECALS</b>	<b>17 &amp; 18</b>
<b>PARTS LISTS</b>	<b>20 - 26</b>



# INTRODUCTION

Thank you for choosing this Timberwolf brushwood chipper. Timberwolf chippers are designed to give safe and dependable service if operated according to the instructions.

## **IMPORTANT HEALTH AND SAFETY INFORMATION**

**Before using your new chipper, please take time to read this manual which contains and explains the chipper controls. Failure to do so could result in:**

- PERSONAL INJURY
- EQUIPMENT DAMAGE
- DAMAGE TO PROPERTY
- A MEMBER OF THE GENERAL PUBLIC BECOMING INJURED

This manual covers the operation and maintenance of the Timberwolf TW PTO/100G. All information in this manual is based on the latest product information available at the time.

All the information you need to operate the machine safely and effectively is contained within pages 2 to 10. Ensure that all operators are **properly trained** for operating this machine, especially with regard to **safe working practices**.

Timberwolf's policy of constantly improving their products may involve major or minor changes to the chippers or their accessories. Timberwolf reserves the right to make changes at any time without notice and without incurring any obligation.

Due to improvements in design and performance during production there may be, in some cases, minor discrepancies between the actual chipper and the text in this manual.

**The manual should be considered a permanent part of the machine and should remain with it if the machine is resold.**

***ALWAYS FOLLOW SAFE OPERATING AND MAINTENANCE PRACTICES***



## **CAUTION or WARNING**

***BE AWARE OF THIS SYMBOL AND WHERE SHOWN, CAREFULLY FOLLOW THE INSTRUCTIONS.***

This caution symbol indicates important safety messages in this manual. When you see this symbol, be alert to the possibility of injury to yourself or others, and carefully read the message that follows.



# The Timberwolf TW PTO/100G

The Timberwolf PTO/100G brushwood chipper is designed to chip solid wood material including timber branches, saplings and brushwood up to 100mm in diameter.

The Timberwolf PTO/100G brushwood chipper is required to be securely coupled to the pin hitch of an 18 - 40hp compact tractor unit with 540rpm PTO when in use. Power from the attached compact tractor unit is to be supplied to the chipper via PTO drive shaft.

## DIMENSIONS

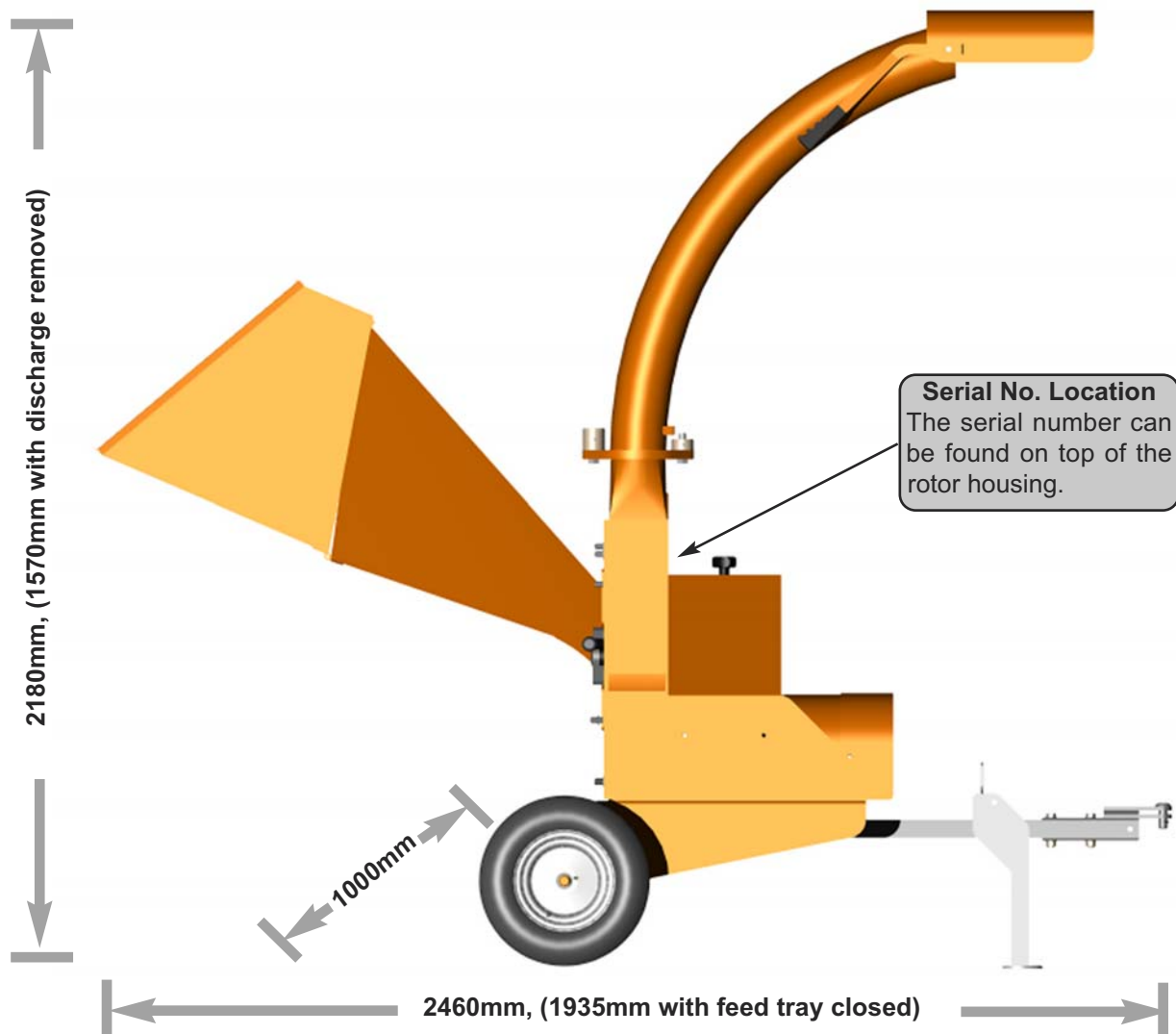

### TIMBERWOLF TW PTO/100G SPECIFICATION

Power source	<i>Tractor PTO drive</i>	Maximum diameter material	100 mm (4")
PTO speed	540rpm	Material processing capacity	1 tonne/hr
Overall weight	270kg	Required engine power	18 - 40hp
Type of feed	<i>Gravity</i>		



# PARTS LOCATOR

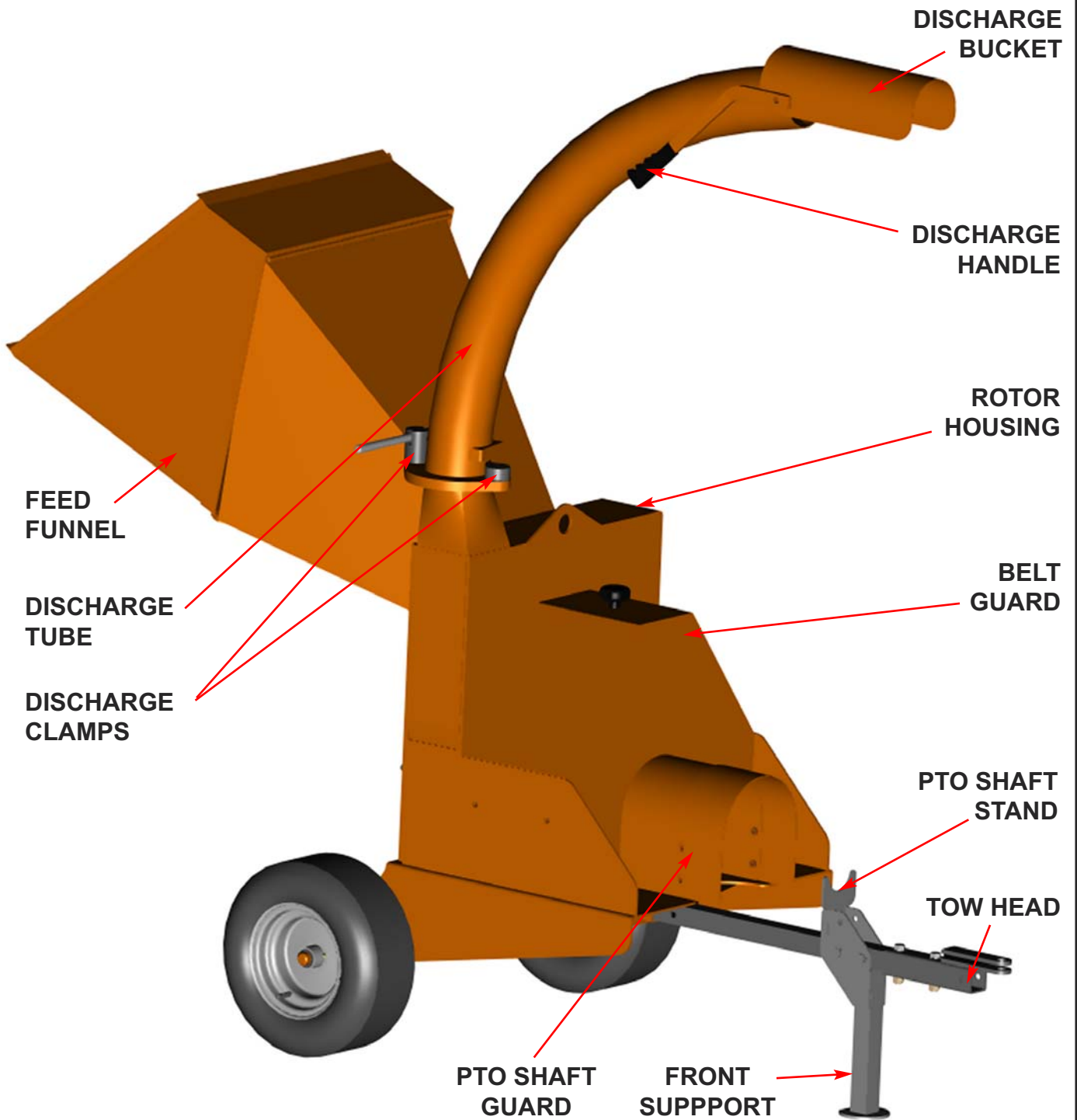



## PARTS LOCATOR

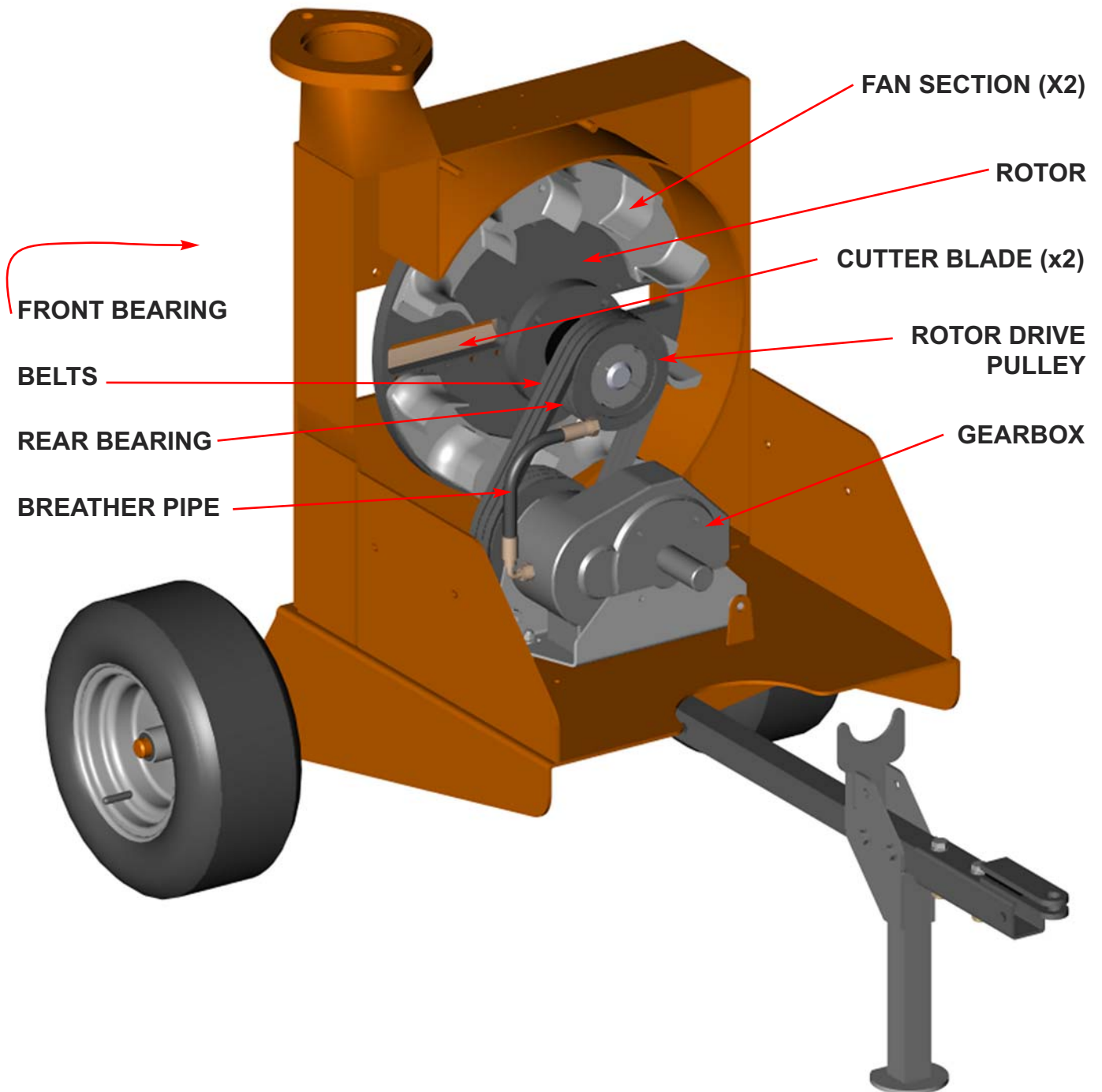



## WARNING

The chipper will feed material through on its own. To do this, it relies on sharp blades both on the feed rollers and the chipper rotor. To keep the blades sharp, only feed the machine with clean brushwood. **DO NOT** put muddy/dirty wood, roots, potted plants, bricks, stones or metal into the chipper.



## OPERATOR'S PERSONAL PROTECTIVE EQUIPMENT REQUIRED



Chainsaw safety helmet fitted with mesh visor and recommended ear defenders to the appropriate specifications.



Close fitting heavy-duty non-snag clothing.



Work gloves with elasticated wrist.



Face mask if appropriate.



Steel toe cap safety boots.



**DO NOT** wear rings, bracelets, watches, jewellery or any other items that could be caught in the material and draw you into the chipper.

## BASIC WOODCHIPPING SAFETY

*The operator should be aware of the following points:*

- **MAINTAIN A SAFETY EXCLUSION ZONE** around the chipper of at least 10 metres for the general public or employees without adequate protection. Use hazard tape to identify this working area and keep it clear from debris build up. Chips should be ejected away from any area the general public have access to.
- **HAZARDOUS MATERIAL** - Some species of trees and bushes are poisonous. The chipping action can produce vapour, spray and dust that can irritate the skin. This may lead to respiratory problems or even cause serious poisoning. Check the material to be chipped before you start. Avoid confined spaces and use a facemask if necessary.
- **BE AWARE** when the chipper is processing material that is an awkward shape. The material can move from side to side in the funnel with great force. If the material extends beyond the funnel, the brush may push you to one side causing danger. Badly twisted brush should be trimmed before being chipped to avoid thrashing in the feed funnel.
- **BE AWARE** that the chipper can eject chips out of the feed funnel with considerable force. Always wear full head and face protection.
- **ALWAYS** work on the side of the machine furthest from any local danger, e.g. not road side.





## GENERAL SAFETY MATTERS



### DO'S AND DON'TS



**ALWAYS** stop the tractor engine, remove ignition key and disconnect the PTO shaft before making any adjustments.

**ALWAYS** check machine has stopped rotating and remove tractor ignition key before maintenance of any kind, or whenever the machine is to be left unattended.

**ALWAYS** check machine is securely coupled to tractor pin hitch and on firm level ground.

**ALWAYS** run tractor engine at required speed to achieve correct PTO speed.

**ALWAYS** check (visually) for fluid leaks.

**ALWAYS** take regular breaks. Wearing personal protective equipment for long periods can be tiring and hot.

**ALWAYS** keep hands, feet and clothing out of feed opening, discharge and moving parts.

**ALWAYS** use the next piece of material or a push stick to push in short pieces. Under no circumstances should you reach into the funnel.



**ALWAYS** keep the operating area clear of people, animals and children.

**ALWAYS** keep the operating area clear from debris build up.

**ALWAYS** keep clear of the chip discharge tube. Foreign objects may be ejected with great force.

**ALWAYS** ensure protective guarding is in place before commencing work. Failure to do so may result in personal injury or loss of life.

**ALWAYS** operate the chipper in a well ventilated area - exhaust fumes are dangerous.

**DO NOT** operate chipper unless available light is sufficient to see clearly.

**DO NOT** attempt to engage PTO without the feed funnel, belt guard, guards and discharge unit securely in place.

**DO NOT** stand directly in front of the feed funnel when using the chipper. Stand to one side.

**DO NOT** allow -



BRICKS STRING CLOTH PLASTIC STONES



METAL GLASS RUBBER ROOTS BEDDING PLANTS

- to enter the machine, as damage is likely.

**DO NOT** smoke when refuelling.



**DO NOT** let anyone who has not received instruction operate the machine.

**DO NOT** climb on the machine at any time.

**DO NOT** handle material that is partially engaged in the machine.

**DO NOT** touch any exposed wiring while machine is running.

**DO NOT** use the chipper inside buildings.



## NOISE TEST

**MACHINE:** TW PTO/100G

**NOTES:** Tested chipping green conifer 25 mm-40 mm

*Noise levels above 80dB (A) will be experienced at the working position. Wear ear protection at all times to prevent possible damage to hearing. All persons within a 4 metre radius must also wear good quality ear protection.*

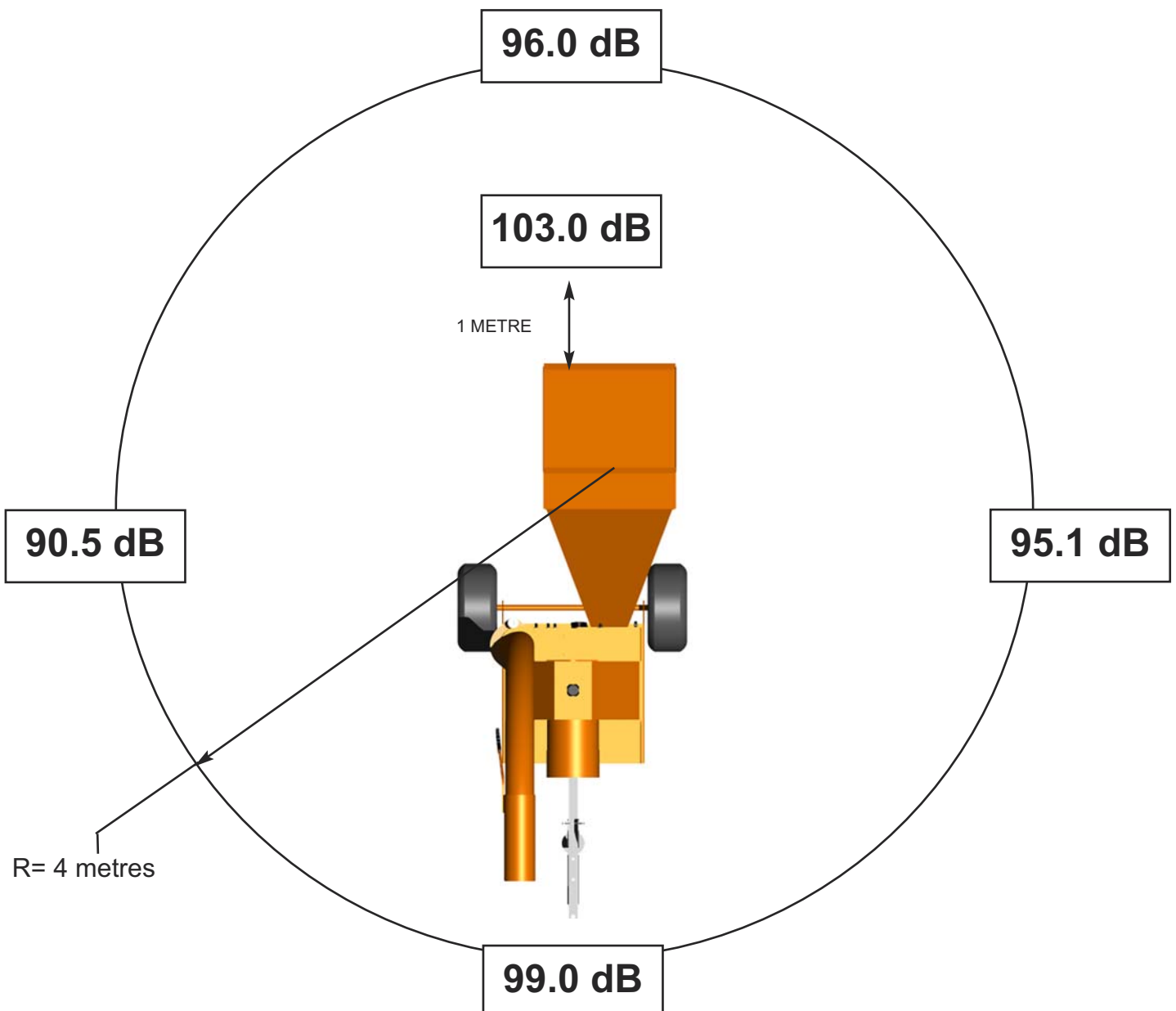





## DELIVERY

All Timberwolf TW PTO/100G machines have a full pre - delivery inspection before leaving the factory and are ready to use. Read and understand this instruction manual before attempting to operate the chipper. In particular, read pages 5-7 which contain important health and safety information and advice.

## SAFE TRANSPORTATION

- THE PTO/100G chipper may be transported as a unit or with the feed funnel removed.
- TAKE care when loading the PTO/100G as it is 268kg in weight.
- STRAP the chipper down firmly before beginning a journey.

## OPERATOR'S PERSONAL PROTECTIVE EQUIPMENT REQUIRED

- CHAINSAW safety helmet fitted with visor and recommended ear defenders to an appropriate specification.
- HEAVY-DUTY gloves with elasticated wrist area.
- CLOSE - FITTING heavy-duty non-snap clothing.
- SAFETY footwear.
- FACE MASK (if appropriate).

See page 5 for more detailed information.

## HITCHING UP

The PTO/100G is fitted with a pin type hitch. It is suitable for use with a range of compact tractor with a 540rpm PTO output. The chipper tow head is fitted onto the tractor coupling for use with a steel pin (1) which is dropped through the hole. This should be retained with an R clip (2) for security.

The front leg that keeps the chipper level and provides support for the propeller shaft is movable. After hitching to a tractor and fitting the prop shaft the bolt (3) can be removed and the leg swung horizontal. The bolt is then refitted in hole shown (4).

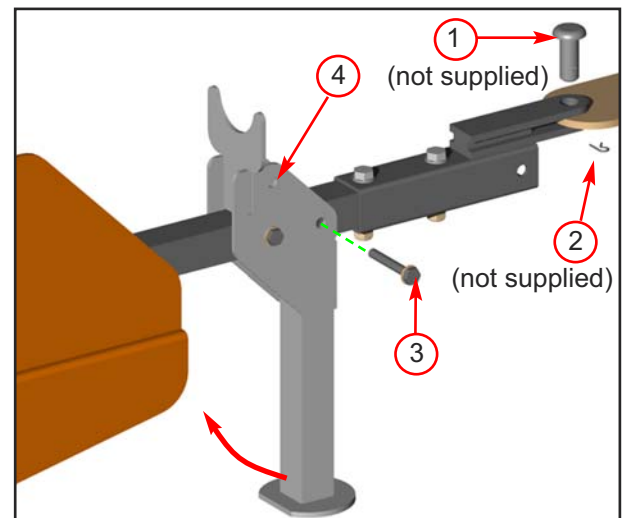
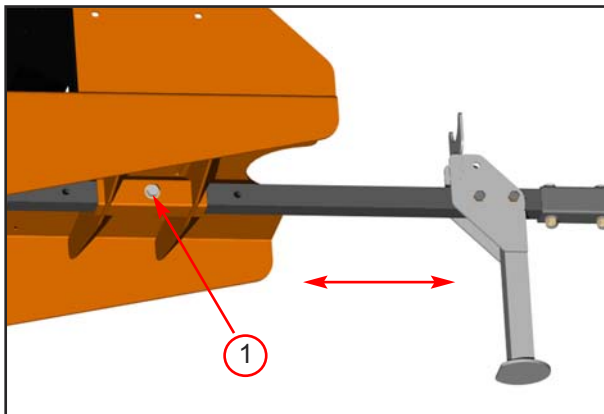

The first time a tractor is fitted to the chipper the correct length of tow beam needs to be set. The length corresponds to the exact propeller shaft that is to be used. Adjustment is made underneath the chipper. Remove the M12 bolt from underneath the chassis (1) and slide the bar until the desired length is reached. Replace the bolt and tighten.

**WARNING**

ALWAYS ENSURE THE TRACTOR ENGINE IS TURNED OFF AND KEY REMOVED FROM IGNITION BEFORE PERFORMING ANY ADJUSTMENTS TO CHIPPER





### CONNECTING PTO SHAFT

**ALWAYS ENSURE THE TRACTOR IS TURNED OFF BEFORE FITTING OR REMOVING PROP SHAFT.**

When fitting a PTO shaft it should always be remembered that 100 mm of overlap is required between the two sections of the shaft. This is the minimum needed to ensure the shaft does not fail.

To connect the PTO shaft follow the instructions supplied with the shaft. The shaft should remain fitted to the chipper at all times. It can be placed on the prop shaft support when the tractor is removed.

### DAILY CHECKS BEFORE STARTING

- LOCATE the machine on firm level ground and correctly coupled to a tractor.
- CHECK all guards are in place and PTO guard anti rotation chain is secured.
- CHECK the discharge unit is pointing in a safe direction.
- CHECK the feed funnel to ensure no objects are inside.

*For parts location see diagrams on pages 3 & 4.*

### STARTING TO CHIP

#### **WARNING**

Do not use or attempt to start the chipper without the protective guarding and discharge unit securely in place. Failure to do so may result in personal injury or loss of life.



- CHECK that the chipper is running smoothly at correct PTO speed.
- STAND to one side of the feed funnel when loading material.
- PROCEED to feed material into the feed funnel (note do's and don't's).

### CHIPPING

Wood up to 100 mm in diameter can be fed into the feed funnel. Enter it into the funnel butt end first. Release the material before it engages the rotor. Some pieces of wood may move around significantly while being chipped.

The wood will be drawn into the cutting blade quite quickly, be ready for this to happen. Stand well clear.

A piece of wood which is too tough or too large for the chipper will slow the engine down. When this happens it is possible to hold back the branches that are being chipped and allow the engine to regain its speed again.

If a piece of wood gets stuck in the funnel and it cannot be chipped due to its size or shape, it will need to be removed. Trim the branch until it is a suitable shape for the chipper to accept.



## BLADE WEAR

The most important part of using a wood chipper is keeping the cutter blades sharp. Timberwolf chipper blades are hollow ground to an angle of 40 degrees. When performing daily blade checks ensure blade edge is sharp and free from chips, if there is any evidence of damage, or the edge is "dull" change the blade(s). The TW 13/75G is fitted with two blades 177 mm (7") long. They are 43 mm wide when new. A new blade should chip for up to 25 hours before it requires sharpening. This figure will be drastically reduced by feeding the machine with stony, sandy or muddy material.

As the blade becomes blunt performance is reduced, with increased stress and load on the machine the chips will become more irregular and stringy. At this point the blade should be sent to a reputable blade sharpening company. The blade can be sharpened several times in its life. A wear mark on the reverse side indicates the safe limit of blade wear. Replace when this line is exceeded.

The machine is also fitted with a static blade (anvil). It is important that the anvil is in good condition to allow the cutting blades to function efficiently. Performance will be poor, even with sharp cutter blades, if the anvil is worn.

## BLOCKAGES

### WARNING

Do not rev engine and increase PTO speed above 540rpm in an attempt to clear blockages. Always follow procedure as outlined below to protect operator and bystanders from ejected material.



Always be aware that what you are putting into the chipper must come out. If the chips stop coming out of the discharge tube but the chipper is taking material in - STOP IMMEDIATELY. Continuing to feed material into a blocked machine may cause damage and will make it difficult to clear.

*If the chipper becomes blocked proceed as follows:*

- STOP the tractor engine and remove the ignition keys.
- ENSURE tractor engine has come to a complete stop.
- REMOVE the discharge tube. Check that it is clear.
- WEARING gloves, reach into the rotor housing and scoop out the majority of the debris causing the blockage.

### WARNING

Do not reach into the rotor housing with unprotected hands. There are sharp blades and any small movement of the rotor may cause serious injury.



- REPLACE the discharge tube.
- RESTART the tractor engine and increase revs to achieve PTO speed of 540 rpm.
- ALLOW machine time to clear excess chips still remaining in rotor housing before you continue feeding brushwood. Feed in a small piece of wood while watching to make sure that it comes out of the discharge. If this does not clear it, repeat the process and carefully inspect the discharge tube to find any obstruction.

### NOTE

Continuing to feed the chipper with brushwood once it has become blocked will cause the chipper to compact the chips in the rotor housing and it will be difficult and time consuming to clear.

**AVOID THIS SITUATION - WATCH THE DISCHARGE TUBE AT ALL TIMES.**



**THE FOLLOWING PAGES DETAIL ONLY  
BASIC MAINTENANCE GUIDELINES SPECIFIC  
TO YOUR CHIPPER.**



**THIS IS NOT A WORKSHOP MANUAL.**

THE FOLLOWING GUIDELINES ARE NOT EXHAUSTIVE AND DO NOT EXTEND TO GENERALLY ACCEPTED STANDARDS OF ENGINEERING/MECHANICAL MAINTENANCE THAT SHOULD BE APPLIED TO ANY PIECE OF MECHANICAL EQUIPMENT AND THE CHASSIS TO WHICH IT IS MOUNTED.

AUTHORISED TIMBERWOLF SERVICE AGENTS ARE FULLY TRAINED IN ALL ASPECTS OF TOTAL SERVICE AND MAINTENANCE OF TIMBERWOLF WOOD CHIPPERS. YOU ARE STRONGLY ADVISED TO TAKE YOUR CHIPPER TO AN AUTHORISED AGENT FOR ALL BUT THE MOST ROUTINE MAINTENANCE AND CHECKS.

TIMBERWOLF ACCEPTS NO RESPONSIBILITY FOR THE FAILURE OF THE OWNER/USER OF TIMBERWOLF CHIPPERS TO RECOGNISE GENERALLY ACCEPTED STANDARDS OF ENGINEERING/MECHANICAL MAINTENANCE AND APPLY THEM THROUGHOUT THE MACHINE.

**THE FAILURE TO APPLY GENERALLY ACCEPTED  
STANDARDS OF MAINTENANCE, OR THE PERFORMANCE OF  
INAPPROPRIATE MAINTENANCE, MAY INVALIDATE  
WARRANTY IN WHOLE OR IN PART.**

**PLEASE REFER TO YOUR AUTHORISED  
TIMBERWOLF SERVICE AGENT FOR  
SERVICE AND MAINTENANCE.**





## SERVICE SCHEDULE

### WARNING

Always immobilise the machine by stopping the tractor and removing the ignition key before undertaking any maintenance work. When the tractor is stopped it will be necessary to disengage the PTO so that the rotor can be turned.



SERVICE SCHEDULE	Daily Check	25 Hours	50 Hours (once a month)	400 Hours (once a year)
Check feed funnel and belt guard, and PTO guard are securely fitted.	✓			
Check blade condition.	✓			
Check and lubricate PTO shaft.		✓	<i>Refer to PTO leaflet provided.</i>	
Check for tightness all nuts, bolts and fastenings making sure nothing has worked loose.			✓	
Check belt tension, adjust if necessary.			✓	
Check cutting anvil.			✓	
Check wheel grease points.			✓	
Change gear box oil.				✓

**NOTE:** Your Timberwolf woodchipper is covered by a full 12 months parts and labour warranty. Subject to correct maintenance and proper machine usage, the bearings are guaranteed for 12 months regardless of hours worked by the machine. In conditions of 'heavy usage' - i.e. in excess of 500 hours per year - it is recommended that the bearings are changed annually to ensure that the machine retains optimum working performance.

### SPARES

Only fit genuine Timberwolf replacement blades, screws and chipper spares. Failure to do so will result in the invalidation of the warranty and may result in damage to the chipper, personal injury or even loss of life.

### COPPER EASE SAFETY INFORMATION

**Product name: Copper Ease.**

Copper Ease contains no hazardous ingredients at or above regulatory disclosure limits, however, safety precautions should be taken when handling (use of oil-resistant gloves and safety glasses are recommended - respiratory protection is not required). Avoid direct contact with the substance and store in a cool, well ventilated area avoiding sources of ignition, strong oxidising agents and strong acids. Dispose of as normal industrial waste (be aware of the possible existence of regional or national regulations regarding disposal), do not discharge into drains or rivers.

**In case of fire:** in combustion the product emits toxic fumes, extinguish with alcohol or polymer foam, carbon dioxide or dry chemical powder. Wear self-contained breathing apparatus and protective clothing to prevent contact with skin and eyes.

#### FIRST AID

**Skin contact:** there may be mild irritation at the site of contact, wash immediately with plenty of soap and water.

**Eye contact:** there may be irritation and redness, bathe the eye with running water for 15 minutes.

**Ingestion:** there may be irritation of the throat, do not induce vomiting, wash out mouth with water

A safety data sheet for this product can be obtained by writing to the manufacturer at the following address: Comma Oil and Chemicals Ltd., Deering Way, Gravesend, Kent DA12 2QX. Tel: 01474 564311, Fax: 01474 333000.



### SAFE MAINTENANCE

- HANDLE blades with extreme caution to avoid injury. Gloves should always be worn when handling the cutter blades.
- THE drive belts should be connected while changing blades, as this will restrict sudden movement of the rotor.
- THE major components of this machine are heavy. Lifting equipment must be used for disassembly.
- CLEAN machines are safer and easier to service.

### CHECK FITTINGS

The Timberwolf PTO/100G is subject to large vibrations during the normal course of operation. Consequently there is always a possibility that nuts and bolts will work themselves loose. It is important that periodic checks are made to ensure the security of all fasteners. Fasteners should be tightened using a torque wrench to the required torque (see below). **Uncalibrated torque wrenches can be inaccurate by as much as 25%. It is therefore essential that a calibrated torque wrench is used to achieve the tightening torques listed below.**

	Size	Pitch	Head	Torque lbft	Torque Nm
Blade Bolts	M8	Standard	T40 Torq	22	29
Funnel Retaining Nuts	M12	Standard	19 mm Hex	60	80
General	M8	Standard	13 mm Hex	17	23
General	M10	Standard	17 mm Hex	34	46
General	M12	Standard	19 mm Hex	60	80

### TENSION BELTS

**NOTE: There will normally be a rapid drop in tension during run-in period for new belts. When new belts are fitted, check the tension every 2 - 3 hours and adjust until the tension remains constant.**

*Belt failures due to lack of correct tensioning will not be covered under your Timberwolf warranty.*

1. Remove the belt guard.
2. Check the belt tension. For instructions on checking belt tension & correct belt tension values, please refer to the Timberwolf V-Belt Tensioning Data Table (this information can be obtained from your dealer).
3. Loosen the M12 Bolt.
4. Adjust the belt tension by tightening the nut clamping the bracket to the base.
5. Re-tighten the M12 Bolt.
6. Refit belt guard.

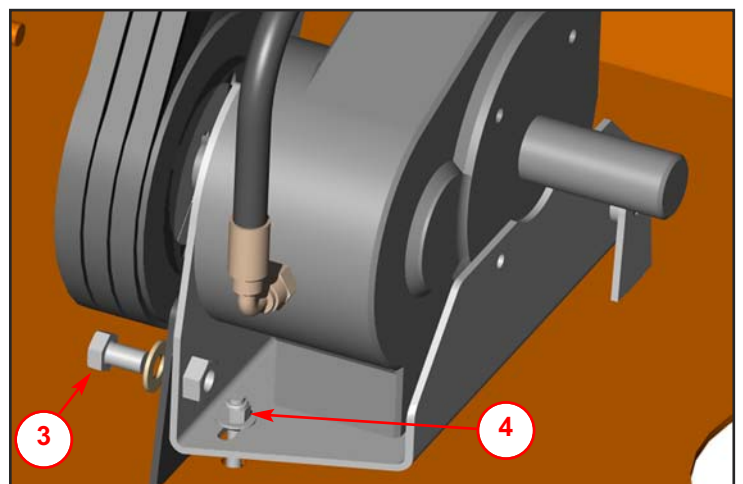

**N.B.** Early models were fitted with a gearbox on a slider. The belt tensioner for these models is located on the slide plate.

### ANVIL CHANGING

The anvil is an important component in maintaining a consistent machine performance. Inspect it with the feed funnel removed. A measure of the wear is how sharp the edge is. If it has become seriously rounded then it is appropriate to change it.

*Turning or replacing the anvil should be carried out by a Timberwolf dealer.*

### CHANGE ROTOR BEARINGS

Return the chipper to your dealer.





## CHANGE BLADES

### WARNING

Wear riggers gloves for the blade changing operation.

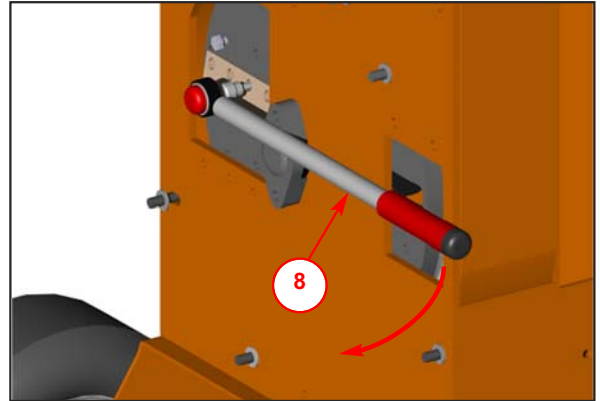
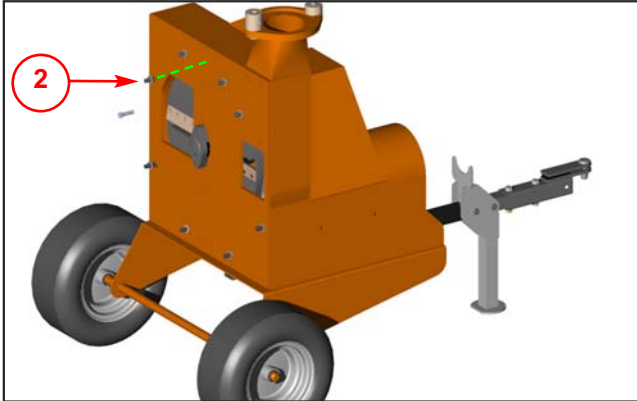

1. Remove the feed funnel.
2. Insert M10 screw into rotor to stop it turning.
3. Use a small screwdriver to remove sap and debris from Torx socket in screw - be particularly careful to ensure every last piece has been removed.
4. Using the Torx fitting provided loosen the blade screws.
5. Remove the blade carefully.
6. **Before fitting a new blade ensure the seating surface on the rotor is spotlessly clean. This is necessary to ensure the blade is always held firm. Damage to the rotor may be caused if this is not checked.**
7. Apply a small amount of copper grease to the blade screws.
8. **Using a torque wrench tighten the blade screws to 29Nm (22 lb/ft).**

### WARNING



Always sharpen blades on a regular basis. Failure to do so will cause the machine to under perform and will overload engine and bearings causing machine breakdown. Blades must not be sharpened beyond the wear mark (see diagram). Failure to comply with this could result in machine damage, injury or loss of life.

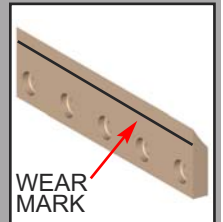

## CHANGE GEAR BOX OIL

1. Remove the belt guard.
2. Locate the drain plug underneath the gear box.
3. Drain out oil and replace plug.
4. Add 560ml oil (EP80/90) via top filler/breather plug.

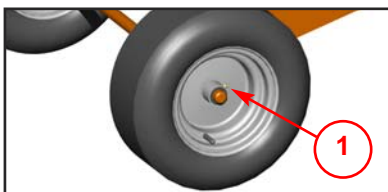
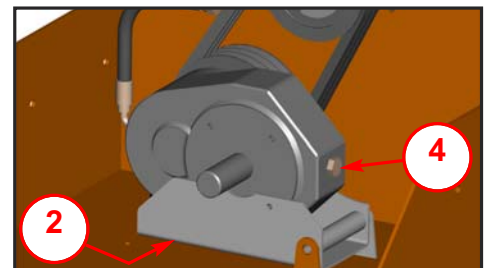

## CHECK WHEEL GREASE POINTS

1. Locate grease nipples attached to wheel hubs.
2. Apply 5 shots of general purpose grease.

## SAFE LIFTING OF THE CHIPPER

The lifting eye is designed to lift the machine's weight only. Do not use hoist hook directly on the lifting eye, use a correctly rated safety shackle. Inspect the lifting eye prior to each use - DO NOT USE LIFTING EYE IF DAMAGED.

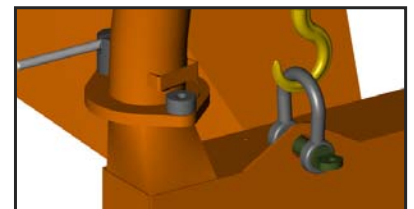



## **ENVIRONMENTAL MANUFACTURING LLP 12 MONTH CHIPPER WARRANTY**

### **WARRANTY PERIOD**

The warranty period for the woodchipper commences on the date of sale to the first end user and continues for a period of 12 months. This guarantee is to the first end user only and is not transferable except when an authorised Timberwolf Dealer has a woodchipper registered with Environmental Manufacturing LLP as a hire chipper or long term demonstrator – in these situations they are duly authorised to transfer any remaining warranty period to their first end user. Any warranty offered by the Timberwolf Dealer beyond the original 12 month period will be wholly covered by said Dealer.

### **LIABILITY**

Our obligation under this warranty is limited to repair at Environmental Manufacturing LLP premises or at our option an Environmental Manufacturing LLP approved Timberwolf dealer. No liability will be accepted for special, indirect, incidental, or consequential loss or damages of any kind.

### **WARRANTY STATEMENT**

Environmental Manufacturing LLP warrants to the first end user that;

- Your woodchipper shall be designed, built and equipped, at the point of sale, to meet all current applicable regulations.
- Your chipper shall be free from manufacturing defects both in materials and workmanship in normal service for the period mentioned above.

Warranty will not apply to a failure where normal use has exhausted the life of a component.

Engine units are covered independently by their respective manufacturer warranties.

### **OWNERS WARRANTY RESPONSIBILITIES**

As the owner of an Environmental Manufacturing LLP woodchipper you are responsible for the following;

- Operation of the woodchipper in accordance with the Environmental Manufacturing LLP instruction manual.
- Performance of the required maintenance listed in your Environmental Manufacturing LLP instruction manual.
- In the event of a failure the Environmental Manufacturing LLP authorised Timberwolf dealer is to be notified within 10 days of failure and the equipment is to be made available for unmolested inspection by the dealer technician.

### **WARRANTY RESTRICTIONS**

The Environmental Manufacturing LLP warranty is restricted to the first end user only and is not transferable except when an authorised Timberwolf Dealer has a woodchipper registered with Environmental Manufacturing LLP as a hire chipper or long term demonstrator – in these situations they are duly authorised to transfer any remaining warranty period to their first end user.

The Environmental Manufacturing LLP warranty may be invalidated if any of the following apply;

- The failed parts or assembly is interfered with in any way.
- Normal maintenance has not been performed.
- Incorrect reassembly of components.
- The machine has undergone modifications not approved in writing by Environmental Manufacturing LLP.
- In the case of tractor driven equipment, use has been on an unapproved tractor.
- Conditions of use can be deemed abnormal.
- The machine has been used to perform tasks contrary to those stated in the Environmental Manufacturing LLP instruction manual.

### **WARRANTY SERVICE**

To obtain warranty service please contact your nearest Environmental Manufacturing LLP approved Timberwolf dealer. To obtain details of the nearest facility please contact Environmental Manufacturing LLP at the address on the front of this manual.

These warranty terms are in addition to and not in substitution for and do not affect any right and remedies which an owner might have under statute or at common law against the seller of the goods under the contract by which the owner acquired the goods.



# CERTIFICATE OF CONFORMITY

## Environmental Manufacturing LLP

Entec House,  
Tomo Industrial Estate,  
Stowmarket,  
Suffolk IP14 5AY

Tel: 01449 765800 Fax: 01449 765801

### EC Declaration of Conformity



Environmental Manufacturing LLP as the designer and manufacturer, certifies that the machine stipulated below complies with all the relevant provisions of the:

### Machinery Directive; 2006/42/EC (& other relevant directives)

and the National Laws and Regulations adopting these directives.

Designer/Manufacturer : Environmental Manufacturing LLP

Description of Machinery : Un-powered, inter-changeable machine designed to be coupled to the pin hitch of a tractor unit with a suitable 540 rpm PTO power source for the purpose of chipping up tree waste prior to disposal.

Model : TW PTO 100 G

Serial No. : Serial Manufacture

BSI Transposed Harmonised Standards applied: (including parts/clauses of):

BS EN 12100-1: 2003 Safety of Machinery- Basic concepts, BS EN 13857-1: 2008 Safety of Machinery-Safety distances to danger zones, BS EN 60204-1: 1998 Safe electrical practices, BS EN 13732-1:2006 Safety of Machinery – Temperatures of touchable surfaces, BS EN 13849-1: 2008 – Safety of Machinery – Safety related parts of control systems, BS EN 982: 1996 – Safety of Machinery – Hydraulics, BS EN 1088: 1995 – Safety of Machinery – Interlocking devices, BS EN 13525: 2005 – Forestry Machinery – Wood chippers – Safety.

"Responsible" Person empowered to sign:  Mr. Jeff Haines

Position in Company: Technical Director

Date: 1<sup>st</sup> January 2010



# IDENTIFICATION PLATE

	ENVIRONMENTAL MANUFACTURING LLP STOWMARKET, SUFFOLK IP14 5AY UK		
MODEL	<input type="text"/>		
SERIAL NO.	<input type="text"/>		
CARR. TYP/SN.	<input type="text"/>	GROSS WEIGHT	<input type="text"/>
NOM. POWER	<input type="text"/>	DATE	<input type="text"/>

**EXAMPLE**

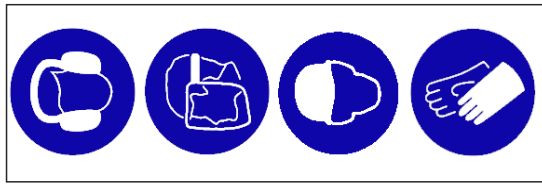

617

670

671

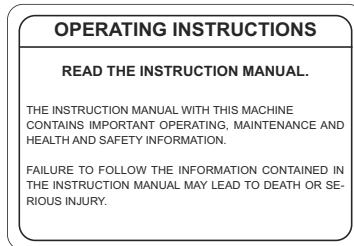

1363

1662

1849

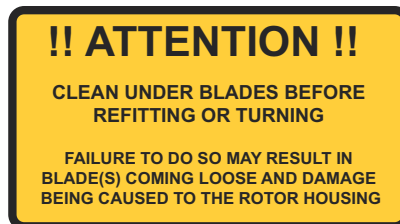
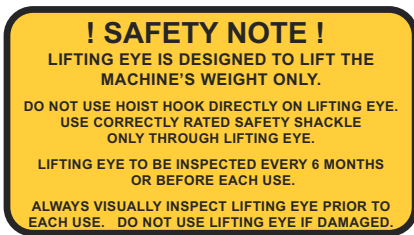

2949

3022

4099



18393

19330

19331

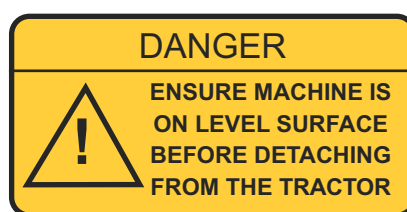

**TIMBERWOLF  
TW PTO/100G**









19334

19343

P0000161



671 - these individual decals are supplied as a set, they may not all apply to your machine.

<p><b>DANGER</b></p> <p>DO NOT OPERATE WITHOUT THIS COVER IN PLACE</p> 	<p><b>DANGER</b></p> <p>AUTOFEED SYSTEM FITTED. ROLLERS MAY TURN WITHOUT WARNING! WHEN ENGINE IS SWITCHED OFF THE ROLLERS WILL TURN DURING THE RUN DOWN PERIOD</p> 	<p><b>CAUTION</b></p> <p>WHEN TRANSPORTING DISCHARGE CLAMPS MAY WORK LOOSE. CHECK FREQUENTLY</p>
<p><b>DANGER</b></p> <p>DO NOT OPERATE WITHOUT THIS COVER IN PLACE</p> 	<p>FUEL HERE </p> <p>RISK OF FIRE</p> <p>ALLOW ENGINE TO COOL FOR 1 MINUTE BEFORE REFUELING. USE UNLEADED PETROL</p>	<p><b>CAUTION</b></p> <p>AVOID STANDING DIRECTLY IN FRONT OF FEED FUNNEL TO REDUCE EXPOSURE TO NOISE, DUST AND RISK FROM EJECTED PARTICLES</p>
<p><b>DANGER</b></p> <p>DO NOT OPERATE WITHOUT THIS COVER IN PLACE</p> 	<p><b>CAUTION</b></p> <p>DO NOT PUT ROAD SWEEPINGS IN MACHINE AS GRIT WILL DAMAGE BLADES</p>	<p><b>DANGER</b></p> <p>ROTATING BLADES</p> 
<p><b>DANGER</b></p> <p>DO NOT OPERATE WITHOUT THIS COVER IN PLACE</p> 	<p><b>DANGER</b></p> <p>STOP ENGINE AND REMOVE KEY BEFORE REMOVING DISCHARGE UNIT. ROTATING BLADES INSIDE.</p> 	<p><b>DANGER</b></p> <p>DO NOT USE THIS MACHINE WITHOUT THE DISCHARGE UNIT FITTED FAILURE TO COMPLY MAY RESULT IN SERIOUS INJURY OR DAMAGE</p> 





# **PARTS LISTS**

*The following illustrations are for parts identification only. The removal or fitting of these parts may cause a hazard and should only be carried out by trained personnel.*

	<i>Page No.</i>
<b>CHASSIS / ROTOR HOUSING</b>	<b>21</b>
<b>DECALS</b>	<b>See pages 18 &amp; 19</b>
<b>DISCHARGE</b>	<b>22</b>
<b>DRIVE TRAIN</b>	<b>23</b>
<b>FUNNEL / BELT GUARD</b>	<b>24</b>
<b>ROTOR</b>	<b>25</b>
<b>V- BELT TENSIONING TABLE</b>	<b>26</b>

# 21 CHASSIS/ROTOR HOUSING



**TIMBERWOLF**  
**TW PTO 100G**

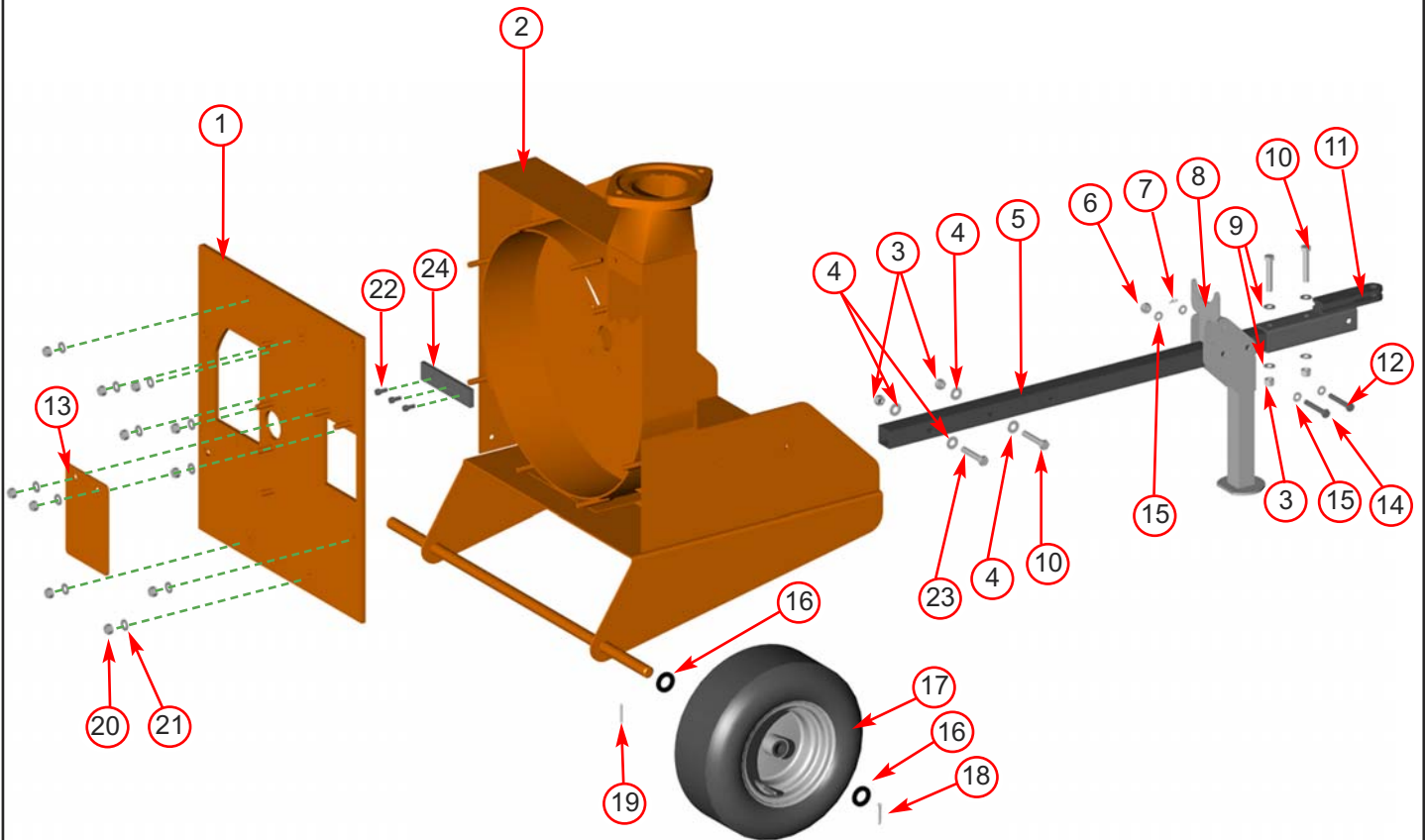

Date Last Modified: 24th Jan 08

Item	Part No	Part Name	Q'ty	Item	Part No	Part Name	Q'ty
1	1096FO	Front Plate	1	13	0524P	Access Cover	1
2	18454FO	Rotor Housing	1	14	0371	M10/70 Bolt	2
3	0644	M12 P Nyloc Nut	4	15	0701	M10 A Washer	4
4	0704	M12 C Washer	4	16	0707	M24 A Washer	4
5	1021MB	Tow Beam	1	17	1025	Wheel	2
6	0052	M10 T Nyloc Nut	1	18	0528	Split Pin	2
7	4094	R Clip	1	19	0068	Roll Pin	2
8	1020FB	Prop Leg	1	20	0045	M12 T Nut	11
9	0702	M12 A Washers	4	21	0702	M12 A Washers	11
10	0334	M12/70 Bolt	3	22	0345	M8/18 Socket Caps	3
11	1022FB	Tow Hitch	1	23	0987	M12/60 Bolt	1
12	<i>made in production</i>	Prop Leg Pin	1	24	0105MH	Anvil	1

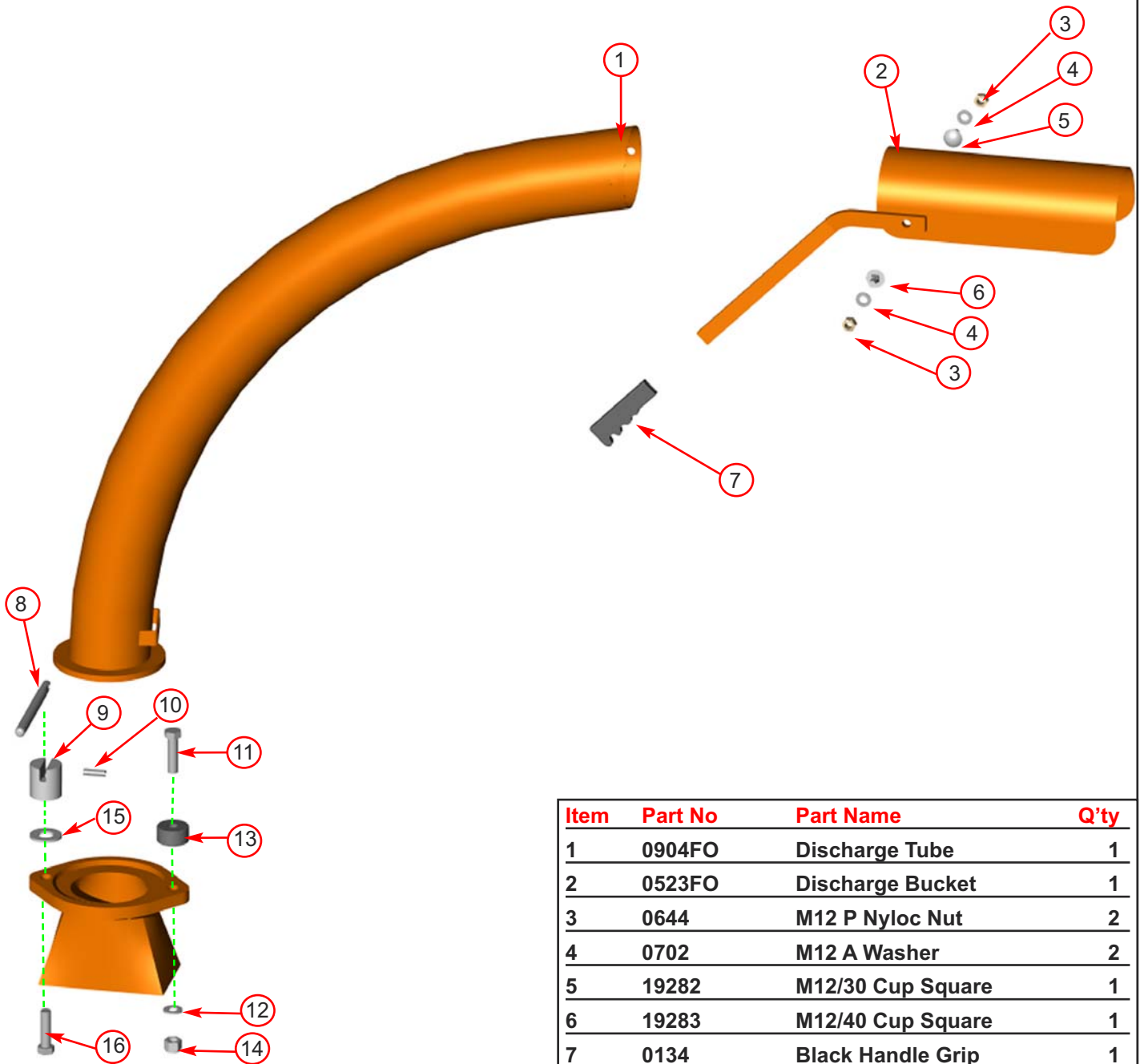

Item	Part No	Part Name	Q'ty
1	0904FO	Discharge Tube	1
2	0523FO	Discharge Bucket	1
3	0644	M12 P Nyloc Nut	2
4	0702	M12 A Washer	2
5	19282	M12/30 Cup Square	1
6	19283	M12/40 Cup Square	1
7	0134	Black Handle Grip	1
8	1649MS	Discharge Clamp Handle	1
9	4109M	M16 Clamp Nut	1
10	4131	Roll Pin	1
11	0434	M16/70 Hex Bolt	1
12	1354	M16 C Washer	1
13	2837MS	Clamp Nut Small	1
14	1511	M16 P Nyloc Nut	1
15	0832	M24 Washer	1
16	0333	M16/60 Hex Bolt	1

# 23 DRIVE TRAIN



**TIMBERWOLF  
TW PTO 100G**

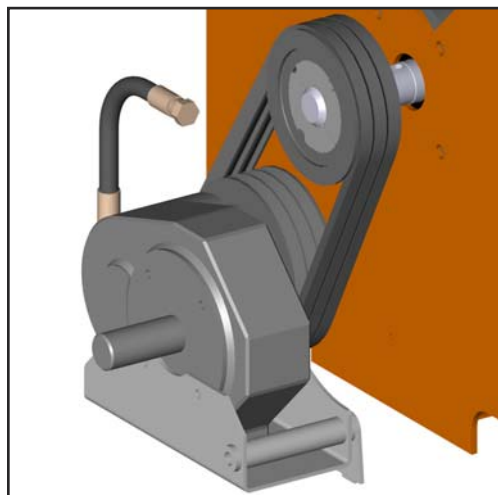
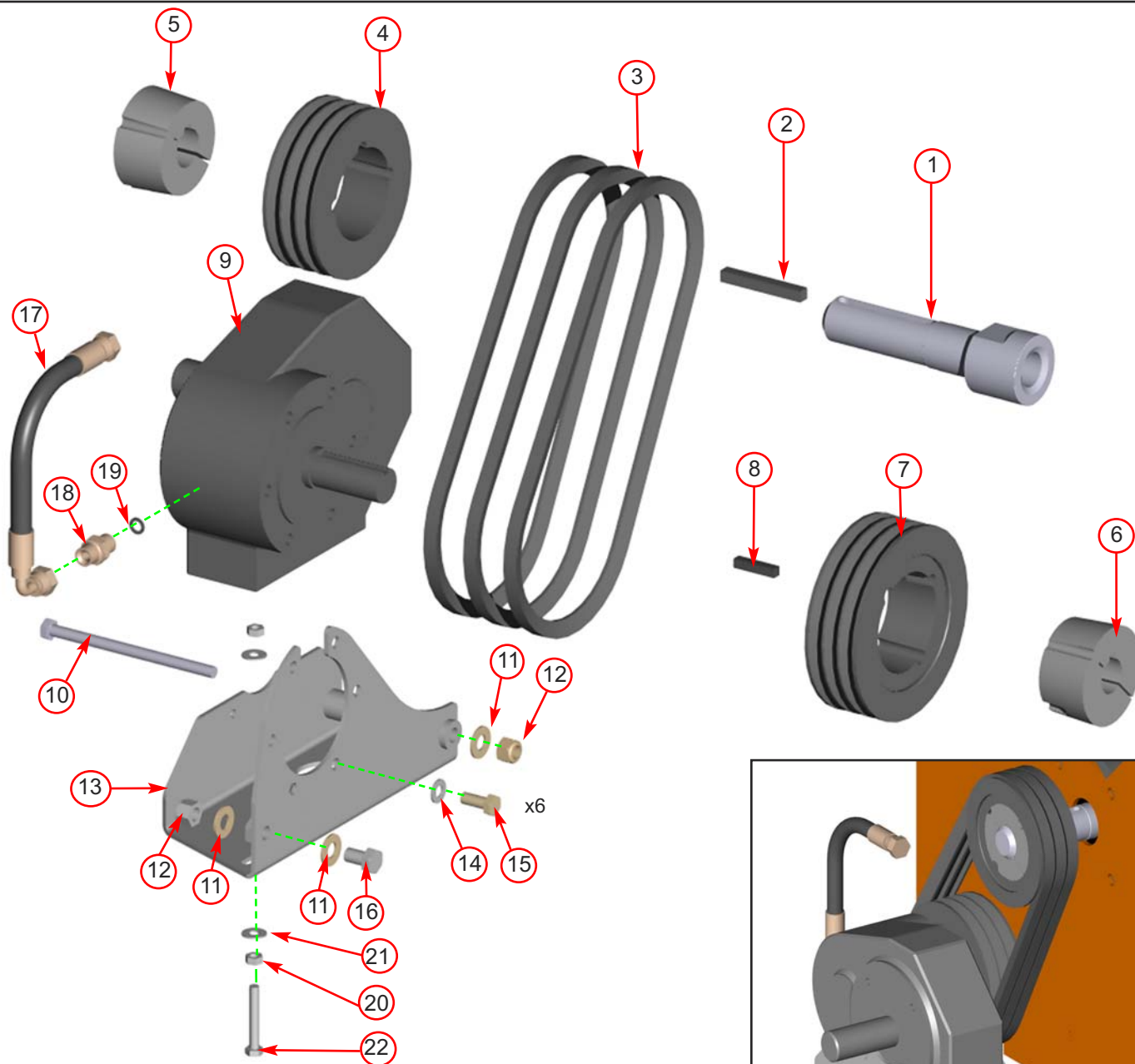

Date Last Modified: 20th Oct 11

Item	Part No	Part Name	Q'ty
1	18947M	Rear Shaft	1
2	18961M	Key 10x8x80	1
3	1533	Belt 900 SPA	3
4	1471	Pulley 140x3 SPA	1
5	0410	Bush 2517 38 mm	1
6	1616	Bush 2517 30 mm	1
7	1175	Pulley 160x3 SPA	1
8	0073	Key 8x8x40	1
9	1617	Gear Box	1
10	0316	M12/150 Bolt	1
11	0704	M12 C Washer	3

Item	Part No	Part Name	Q'ty
12	0644	M12 P Nyloc Nut	2
13	1531FS	Gear Box Bracket	1
14	0701	M10 A Washer	6
15	0360	M10/25 Bolt	6
16	0318	M12/30 Bolt	1
17	4239	3/8" Breather Hose	1
18	0161	3/8" M/M Adapter	1
19	0396	3/8" Dowty Washer	1
20	0476	M8 Plain Nut	2
21	0712	M8 C Washer	2
22	0354	M8/60 Bolt	1

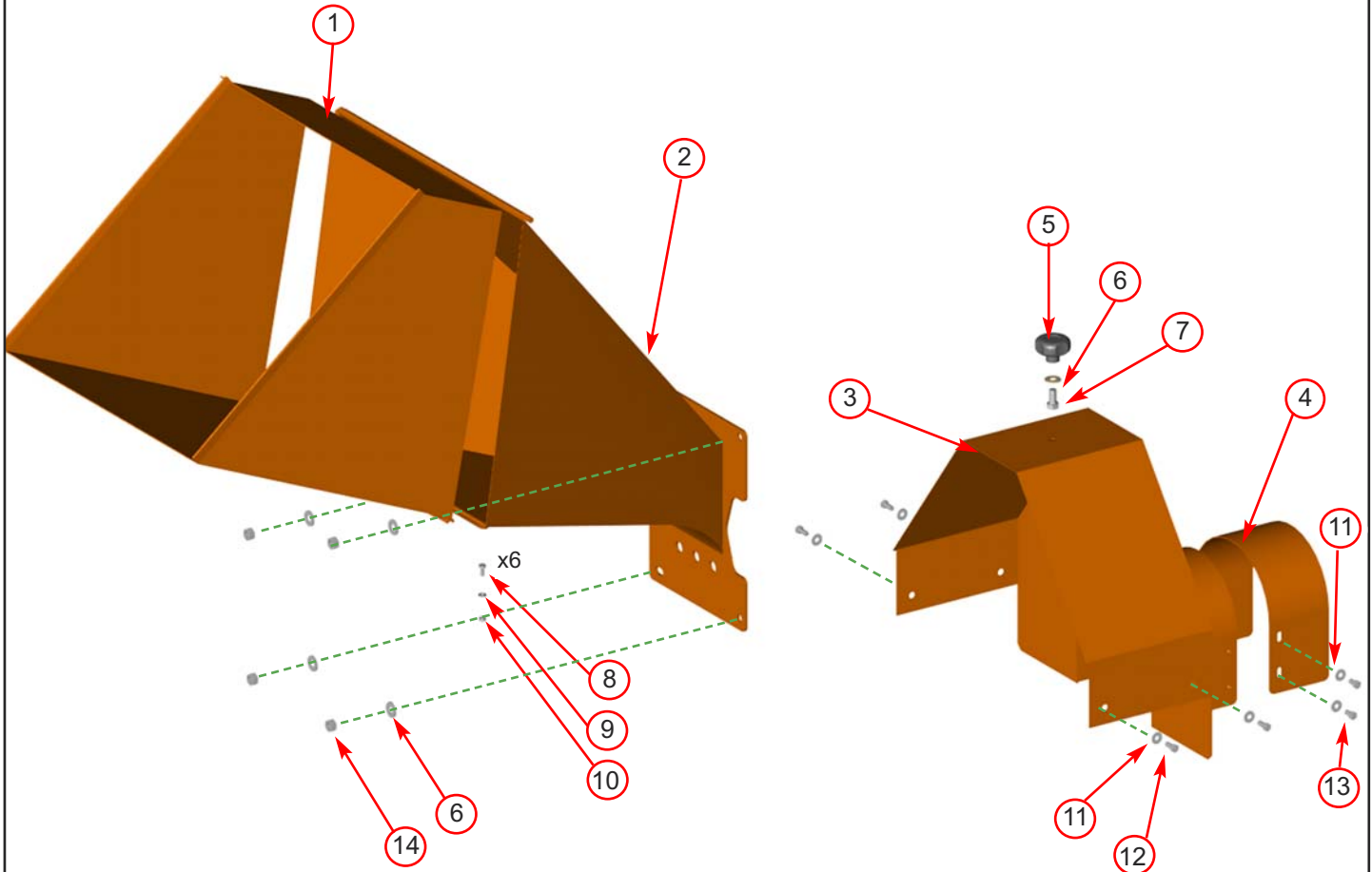

Date Last Modified: 3rd Aug 05

Item	Part No	Part Name	Q'ty	Item	Part No	Part Name	Q'ty
1	0693	Feed Tray	1	8	1415	M6/16 Pan Posi	6
2	0691O	Funnel	1	9	0709	M6 A Washer	6
3	1013FO	Belt Guard	1	10	0391	M6 T Nyloc Nut	6
4	1077FO	Funnel Extension	1	11	0712	M8 C Washer	8
5	0361	Knob	1	12	0346	M8/20 Bolt	4
6	0704	M12 C Washer	4	13	0344	M8/16 Bolt	4
7	0318	M12/20 Bolt	1	14	0046	M12 Plain Nut	4

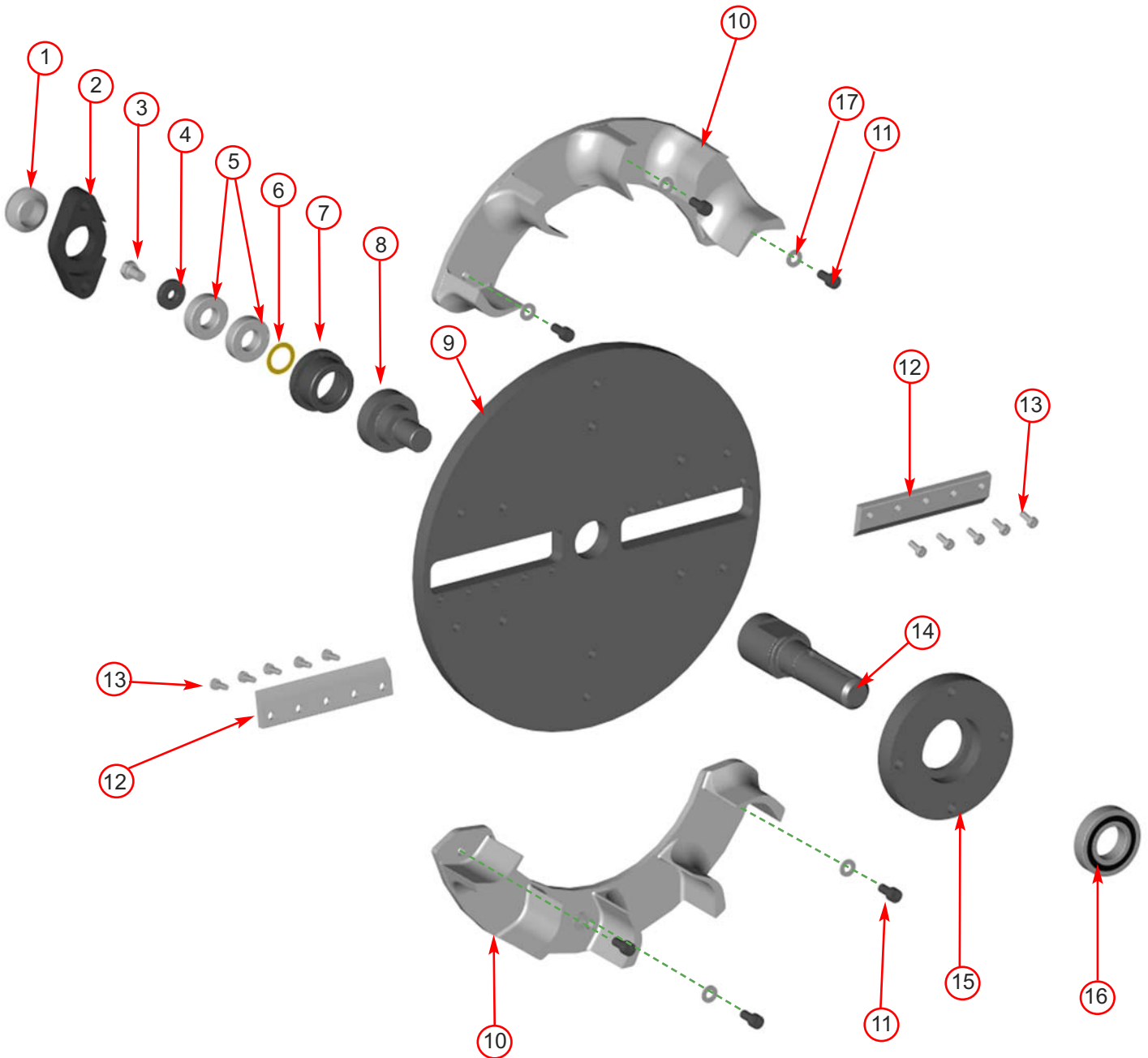

Date Last Modified: 30th Oct 08

Item	Part No	Part Name	Q'ty	Item	Part No	Part Name	Q'ty
1	0959	Plastic Cap	1	10	1571	Fan Section	2
2	0884MS	Front Bearing Housing	1	11	0386	M10/30 Caphead	6
3	0318	M12/20 Hex Set	1	12	0071H	Blade	2
4	0415	Heavy Washer	1	13	0065	Blade Bolts	10
5	0491	Bearing 6205	2	14	0881M	Rear Shaft	1
6	0796	20 Thou Shim	As Req'd	15	4063MCB	Rear Bearing Housing	1
7	0883MCB	Bearing Cup	1	16	0495	Bearing 6208	1
8	1611M	Nose Shaft	1	17	0781	M10 A Washer	6
9	1083M	Rotor	1				





### TIMBERWOLF V-BELT TENSIONING DATA TABLE

**METHOD:**

1. SET THE DEFLECTION DISTANCE ON THE LOWER SCALE OF THE TENSION GAUGE SO THAT THE UNDERSIDE OF THE 'O'-RING EQUALS THE 'h' VALUE GIVEN IN THE TABLE BELOW
2. ENSURE THAT THE DEFLECTION FORCE SCALE IS ZERO'D BY PUSHING THE UPPER 'O'-RING ALL THE WAY DOWN
3. PLACE THE TENSION GAUGE IN THE CENTRE OF THE BELT SPAN AS SHOWN IN THE DIAGRAM LEFT
4. PRESS DOWNWARDS ON THE RUBBER BUFFER, DEFLECTING THE BELT UNTIL THE UNDERSIDE OF THE LOWER 'O'-RING IS LEVEL WITH THE BELT BEHIND (USE A STRAIGHT EDGE IF THERE IS ONLY 1 BELT)
5. TAKE THE READING FROM THE DEFLECTION SCALE OF THE TENSION METER (READ AT THE LOWER EDGE OF THE 'O'-RING) & COMPARE THIS VALUE WITH THAT GIVEN IN THE TABLE BELOW
6. TIGHTEN OR LOOSEN BELTS AS REQUIRED FOLLOWING PROCEDURE GIVEN IN THE OPERATOR'S MANUAL

**TIPS ON BELT TIGHTENING:**

- A) THERE WILL NORMALLY BE A RAPID DROP IN TENSION DURING THE RUN-IN PERIOD FOR NEW BELTS. WHEN NEW BELTS ARE FITTED, CHECK THE TENSION EVERY 2-3 HOURS & ADJUST UNTIL THE TENSION REMAINS CONSTANT
- B) THE BEST TENSION FOR V-BELT DRIVES IS THE LOWEST TENSION AT WHICH THE BELTS DO NOT SLIP OR RATCHET UNDER THE HIGHEST LOAD CONDITION
- C) TOO MUCH TENSION SHORTENS BELT & BEARING LIFE
- D) TOO LITTLE TENSION WILL AFFECT THE PERFORMANCE OF YOUR MACHINE ESPECIALLY IN RESPECT OF NO-STRESS DEVICES
- E) ENSURE THAT BELT DRIVES ARE KEPT FREE OF ANY FOREIGN MATERIALS
- F) IF A BELT SLIPS - TIGHTEN IT!

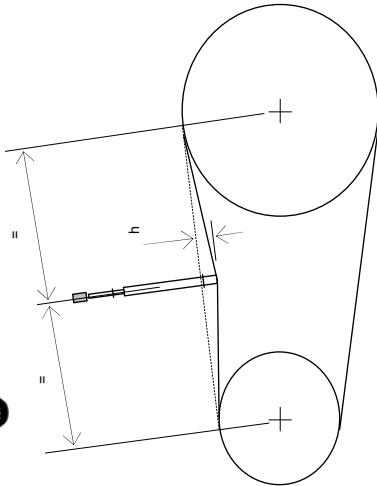

TENSION GAUGES ARE AVAILABLE FROM TIMBERWOLF SPARES, QUOTING PART No. 18091

		ROTOR BELTS											PUMP BELT			
Belt Mfr / Type	TW MODEL No.:	13/75G	18/100G	125PH	150DHB	150VTR	190TDHB	190TFTR 190TVGTR	350DHB(t)	PTO100	PTO150	S426 SHREDDER	S426TFTR SHREDDER	PTO S426 SHREDDER		
Belt Pitch Designation		Gates Super HC-MN	Gates Super HC-MN	Gates Super HC-MN	Gates Super HC-MN	Gates Super HC-MN	Gates Super HC-MN	Gates Super HC-MN	Gates Super HC-MN	Gates Super HC-MN	Gates Super HC-MN	Gates Super HC-MN	Gates Super HC-MN	Gates Super HC-MN		
Belt Length		900.0	1060.0	1060.0	1060.0	1060.0	1232.0	1232.0	2530.0	900.0	900.0	2120.0	2120.0	1700.0		
Belt deflection	=	4.0	4.0	3.5	4.0	4.0	4.0	4.0	8.0	4.0	4.0	8.0	8.0	6.0		
Force reading (Kgf)	New belt	3.4 - 3.6	3.1 - 3.3	3.3 - 3.6	4.3 - 4.5	4.3 - 4.5	3.9 - 4.1	3.9 - 4.1	3.3 - 3.6	3.3 - 3.5	3.8 - 4.0	3.3 - 3.5*	3.3 - 3.5	6.5 - 6.9		
	Used belt	3.0 - 3.2	2.8 - 3.0	2.8 - 3.1	3.7 - 4.0	3.7 - 4.0	3.4 - 3.6	3.4 - 3.6	2.9 - 3.1	2.9 - 3.0	3.3 - 3.5	2.9 - 3.1*	2.9 - 3.1	5.6 - 6.0		
Belt Mfr / Type		N/A	N/A	Gates Super HC-MN	N/A	Gates Super HC-MN	N/A	Gates Super HC-MN	N/A	N/A	Gates Super HC-MN	N/A	Gates Super HC-MN	N/A		
Belt Pitch Designation				SPA		SPA		SPA			SPA		SPA			
Belt Length				925.0		900.0		925.0		925.0			1060.0			
Belt deflection	=			4.0		4.0		4.0		4.0			4.0			
Force reading (Kgf)	New belt			1.9 - 2.0		2.3 - 2.4		2.3 - 2.4		2.0 - 2.2			2.7 - 2.9			
	Used belt			1.7 - 1.8		2.0 - 2.1		2.0 - 2.2		1.8 - 2.0			2.3 - 2.5			